

## **SELF DRILLING SCREWS & RIVETS INTRODUCTION**

<b>COMPANY PROFILE</b>	<b>8</b>
Core Competencies - Manufacturing	10
Technical Competence	12
Quality Assurance	14
Corrosion Protection - Corrosion Environments	16
Corrosion Protection Systems	18
Revolution B8 Coating	20
Bremick Warranty	22
Packaging Options	24
ColourFast Painted Screws	26
<b>SELF DRILLING SCREWS</b>	<b>28</b>
<b>DRIVE BITS &amp; INSERTS</b>	<b>91</b>
<b>RETAIL DISPLAY STANDS</b>	<b>93</b>
<b>SEALANTS &amp; FILLERS</b>	<b>94</b>
Technical Data Self Drilling Screws	95
<b>RIVETS &amp; TOOLS</b>	<b>125</b>
Technical Data - Rivets	152

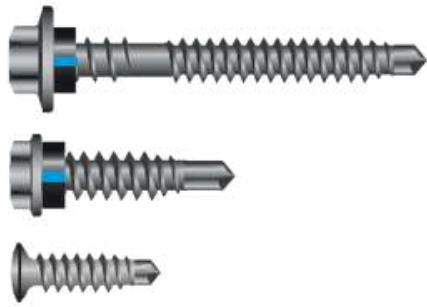

## **VORTEX™ UNIVERSAL SCREWS** 28

Vortex Roofing Solutions	28
Vortex Walling & Cladding Solutions	30
Vortex Framing Solutions	31
Vortex Composite Solutions	32
Vortex Decking Solutions	32

## **SELF DRILLING SCREWS FOR METAL** 3

### **HEXAGONAL HEAD** 3

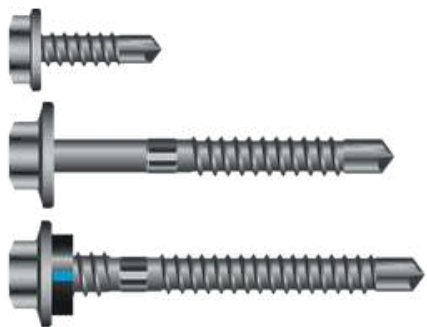

Full Thread – Without Seals	
Part Thread – Without Seals	
Full Thread – With Seals	
Part Thread – With Seals	3
Top Grip Roofing Screws – With Seal	3

### **ROOFING ASSEMBLIES** 5

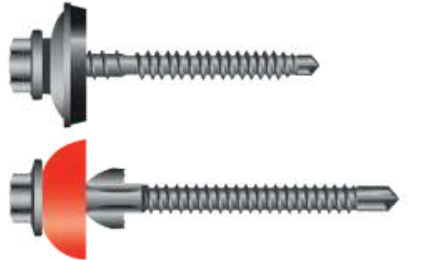

Cyclone Assemblies	3
Poly Carbonate Assemblies	6
Fibre Glass Assemblies	3
Ridge Assemblies	7

### **DEEP DRILLERS – SERIES 5** 3

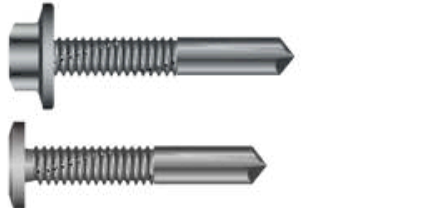

Hexagonal Head – Without Seals	3
Hexagonal Head – With Seals	3
Wafer Head	3

### **WAFER HEAD** 3



Wafer Head	4
------------	---

### **BUTTON HEAD** 3



Button Head	4
-------------	---

### **COUNTERSUNK HEAD** 4



Countersunk Head	3
Countersunk Head – Extended Point	4

**SELF DRILLING SCREWS FOR METAL (cont)**

**COUNTERSUNK RIB HEAD**

49

Countersunk Rib Head

49



Countersunk Rib Head

50

Countersunk Head

51



Self Embedding Head

51



Wing Drillers

51

Extended Point

51



Self Embedding Head

51



Pan Head

52

**BUGLE HEAD**

52

Bugle Head Plaster Board

52



Slotted Hexagonal Head – Without Seal

54

Slotted Hexagonal Head – With Seal

54

Slotted Serrated Head – Without Seal

54













Hexagonal Head – Without Seal

54

Hexagonal Head – With Seal

54



	<b>TYPE 17 SELF DRILLING SCREWS FOR TIMBER</b>	<b>55</b>
	<b>HEXAGONAL HEAD - TYPE 17</b>	<b>5</b>
	Full Thread – Without Seals	
	Part Thread – Without Seals	5
	Full Thread – With Seals	5
	Part Thread – With Seals	5
	Top Grip Roofing Screws – With Seals	6
		5
		<b>7</b>
	Cyclone Assemblies	5
	Poly Carbonate Assemblies	8
	Ridge Assemblies	5
		9
	<b>WAFER HEAD - TYPE 17</b>	<b>5</b>
	Wafer Head	
	<b>BUGLE HEAD TYPE 17</b>	<b>9</b>
	Bugle Batten Screws	6
		1
		6
	<b>SELF EMBEDDING - TYPE 17</b>	<b>6</b>
	Self Embedding – Flower Head	4
	<b>COUNTERSUNK HEAD - TYPE 17</b>	<b>6</b>
	Countersunk Head	
	<b>COUNTERSUNK RIB HEAD - TYPE 17</b>	<b>6</b>
	Countersunk Head	6
		8
	<b>PAN HEAD - TYPE 17</b>	<b>6</b>
	Pan Head Screws	
		9
		6

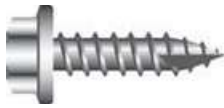

**STAINLESS STEEL SCREWS 7**

Hexagonal Head – Without Seal 7

Hexagonal Head – With Seal 7

Hexagonal Head Cyclone Assemblies – BRA 7

Hexagonal Head Bonded Washer Assemblies 7

Ribbed Bugle Batten 7

Countersunk Rib Head 7

Vortex Deck 1

**HEXAGON SLOTTED NEEDLE POINT**

**BI METAL SELF DRILLING SCREWS FOR METAL**

Hexagonal Head – Without Seal 7

Hexagonal Head – With Seal 7

Cyclone Assemblies – BRA 7

Bonded Washer Assemblies 7

Countersunk Rib Head 3

**BI METAL WAFER HEAD 7**

Wafer Head 7

**BI METAL DEEP DRILLERS**

Hexagonal Head with Seal 3

Hexagonal Head – Without Seal 7

7

7

3



### CHIP BOARD SCREWS 76

Countersunk Rib Head – Needle Point 76



### TREATED PINE SCREWS 78

Countersunk Rib Head – Needle Point 78



Bugle Battens- Type 17 79



Self Embedding Head – Type 17 80



Wing Driller – Countersunk Rib Head 80



### PLASTERBOARD SCREWS 81

Bugle Head – Needle Point 81



Bugle Head – Self Drilling For Metal 82



Laminating Screws 82



### GENERAL PURPOSE SCREWS 83

Button Head – Needle Point 83



Bugle Head – Needle point 84



Pan Head – Needle Point 85



Countersunk Rib Head – Needle Point 85



### COLLATED SCREWS 86

Collated Screws 86



<b>INSULATION SOLUTIONS</b>	<b>88</b>
Insulation Discs & Screws	88

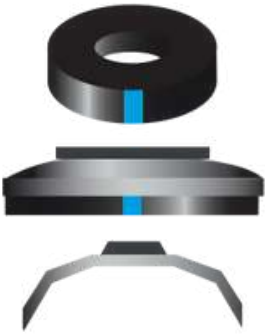

<b>WASHERS &amp; ASSEMBLIES</b>	<b>8</b>
Sealing Washers - EPDM	9
Bonded Washers – EPDM/Aluminium	8
Polycarbonate Seal – EPDM	8
Weather Seals for Fibreglass	8
Cyclone Plates	9
Cyclone Plate Seals – EPDM	8

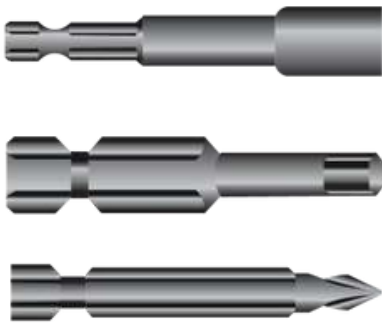

<b>DRIVE BITS &amp; INSERTS</b>	<b>8</b>
Hexagonal Sockets	9
Hexagonal Drive Bits	9
Phillips Drive Bits	0
Magnetic Bit Holder	9
Square Drive Bits	0
Trilobular Drive Bits	0

<b>RETAIL DISPLAY STAND</b>	<b>9</b>
Display Stand & Shelves	9

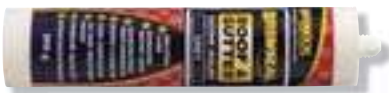

<b>SILICONE SEALANTS AND FILLERS</b>	<b>9</b>
Silicone Sealants	9
Acrylic Gap Filler	1

1  
9  
1  
9  
2  
9  
2  
9  
2



**UNIVERSAL SCREWS ENGINEERED FOR STEEL ROOFING APPLICATIONS**

**vortex™ cyclone**
**UNIVERSAL CYCLONE ASSEMBLIES FOR STEEL & TIMBER**

*For fastening the crest of corrugated and square rib profiles to timber, thin metal battens and steel purlins*

Product Description	Design Features	Pack Quantity	Pack	Product Code	Hexagonal Notes Driver
<b>M6.2</b> -13 x 25	CL4+, W	250		SUHC462025D	<b>5/16</b>
	B8(CAT5), W	250		SUHC862025D	
<b>M6.2</b> -13 x 55	CL4+, TG, W	250	Bulk	SUHC462055D	<b>3/8</b>
	B8(CAT5), TG, W	250	Bulk	SUHC862055D	
<b>M6.2</b> -13 x 65	CL4+, TG, W	250	Bulk	SUHC462065D	
	B8(CAT5), TG, W	250	Bulk	SUHC862065D	
<b>M6.2</b> -13 x 95	CL4+, TG, W	250	Bulk	SUHC462095D	
			Bulk		
			Bulk		

**vortex™ roof**
**UNIVERSAL ROOFING SCREW FOR TIMBER OR METAL**

*For fastening the crest of roof sheeting to thin metal battens, steel purlins or timber*

Product Description	Design Features	Pack Quantity	Pack Type	Product Code	Hexagonal Notes Driver
<b>M6.2</b> -13 x 50	CL4+, TG, W	1000	Bulk	SUHT4620501	<b>5/16</b>
	CL4+, TG, W	100	Trade	SUHT4620507	
	B8(CAT5), TG, W	1000	Bulk	SUHT8620501	
	B8(CAT5), TG, W	100	Trade	SUHT8620507	
<b>M6.2</b> -13 x 65	CL4+, TG, W	500	Bulk	SUHT4620651	
	CL4+, TG, W	100	Trade	SUHT4620657	
	B8(CAT5), TG, W	1000	Bulk	SUHT8620651	
	B8(CAT5), TG, W	100	Trade	SUHT8620657	

**vortex™ corri**
**UNIVERSAL ROOFING SCREW FOR METAL**

*For fastening the crests of corrugated roofing profiles to metal battens or steel up to 1.5mm thick..*

Product Description	Design Features	Pack Quantity	Pack Type	Product Code	Hexagonal Notes Driver
<b>M6.2</b> -13 x 42	CL4+, TG, W	1000	Bulk	SUHT4620421	<b>5/16</b>
	CL4+, TG, W	100	Trade	SUHT4620427	
	B8(CAT5), TG, W	1000	Bulk	SUHT8620421	
	B8(CAT5), TG, W	100	Trade	SUHT8620427	





## UNIVERSAL SCREWS ENGINEERED FOR STEEL WALLING APPLICATIONS

### vortex™ battenfix

#### UNIVERSAL SCREW

*For fastening thin metal battens and ceiling battens to timber or steel*



Product Description	Design Features	Pack Quantity	Pack Type	Product Code	Hexagonal Notes Driver
12g - 11 x 40	CL3+,W	1000	Bulk	SUHC3120402	5/16
	CL3+,W	100	Trade	SUHC3120408	

### vortex™ stitch

*For heavy duty stitching of roofing & walling profiles to steel with sealing washer*



Product Description	Design Features	Pack Quantity	Pack Type	Product Code	Hexagonal Notes Driver
M6.5 -13 x 20	CL4+,W	500	Bulk	SUHC4650201	5/16

## UNIVERSAL SCREWS ENGINEERED FOR STEEL WALLING APPLICATIONS

### vortex™ poly

#### UNIVERSAL POLYCARBONATE ASSEMBLY FOR TIMBER OR STEEL

*For fastening the crests of Polycarbonate roof sheeting to timber battens or steel.*



Product Description	Design Features	Pack Quantity	Pack Type	Product Code	Hexagonal Notes Driver
M6.2 - 13 x 50	CL4+, W	250	Bulk	SUHT462050P	5/16
		100	Trade	TUHT462050P	
M6.2 - 13 x 65	CL4+, W	250	Bulk	SUHT462065P	
		100	Trade	TUHT462065P	

### vortex™ fibreglass

#### METAL DRILLING FIBERGLASS ASSEMBLY FOR STEEL

*For fastening the crests of Fibreglass roof sheeting to steel purlins.*



Product Description	Design Features	Pack Quantity	Pack Type	Product Code	Hexagonal Notes Driver
12g - 13 x 65	CL4+, W	250	Bulk	SMHC412065G	5/16
		100	Trade	TMHC412065G	

## UNIVERSAL SCREWS ENGINEERED FOR STEEL WALLING APPLICATIONS



vortexclad™

**10g HEAD WITH 12g SHANK - WITHOUT SEAL***For fastening the valley of steel walling profilesto steel or timber*

Product Description	Design Features	Pack Quantity	Pack Type	Product Code	Hexagonal Notes Driver
M5.4 - 14 x 25	CL4, W	500	Bulk	SUHC4540252	5/16
	B8(CAT5),W	500	Bulk	SUHC8540252	



vortexclad™

**10g HEAD WITH 12g SHANK - WITH SEAL***For fastening the valley of steel walling profiles to steel or timber*

Product Description	Design Features	Pack Quantity	Pac	Product Code	Hexagonal Notes Driver
M5.4 - 14 x 25	CL4, W	500	Bulk	SUHC4540251	5/16
	B8(CAT5),W	500	Bulk	SUHC8540251	



vortexclad™

**12g HEAD WITH 14g SHANK - WITHOUT SEAL***For fastening the valley of steel walling profilesto steel or timber*

Product Description	Design Features	Pack Quantity	Pac	Product Code	Hexagonal Notes Driver
M6.2 - 13 x 25	CL4, W	500	Bulk	SUHC4620252	5/16
	B8(CAT5),W	500	Bulk	SUHC8620252	



vortexclad™

**12g HEAD WITH 14g SHANK - WITH SEAL***For fastening the valley of steel walling profilesto steel or timber*

Product Description	Design Features	Pack Quantity	Pac	Product Code	Hexagonal Notes Driver
M6.2 - 13 x 25	CL4, W	500	Bulk	SUHC4620251	5/16
	B8(CAT5),W	500	Bulk	SUHC8620251	

vortexmini™  
RAISED PHILLIPS HEAD CL3*For fastening the valley of mini-corrugated sheeting to steel or timber*

Product Description	Design Features	Pack Quantity	Pack Type	Product Code	Phillips Driver	Notes
---------------------	-----------------	---------------	-----------	--------------	-----------------	-------



HIGH PERFORMANCE SCREWS SPECIFICALLY DEVELOPED FOR APPLICATION IN PRE ENGINEERED BUILDING SYSTEMS

## vortex™shed

12g HEX HEAD WITH 14g SHANK

*For heavy duty framing applications*



Product Description	Design Features	Pack Quantity	Pack Type	Product Code	Hexagonal Notes Driver
<b>M6.2</b> -13 x 22	CL4+,W	500	Bulk	SUHC4620222	<b>5/16</b>
	CL4+,W	100	Trade	SUHC4620228	
	B8(CAT5),W	500	Bulk	SUHC8620222	
	B8(CAT5),W	100	Trade	SUHC8620228	

## vortex™truss

12g HEX HEAD WITH 17g SHANK

*Hex Head with Trilobular Vortex Thread with a Cone Point for heavy duty fastening through predrilled holes in steel*



Product Description	Design Features	Pack Quantity	Pack Type	Product Code	Hexagonal Notes Driver
17g - 13 x 18	CL2+	500	Bulk	SUHC2170182	<b>3/8</b>
	CL4+,W	500	Bulk	SUHC4170182	

## vortex™frame

*Ultra flat head with trilobular Vortex thread with a cone point for fastening light steel sections through 3 to 3.5mm pre-drilled holes*



Product Description	Design Features	Pack Quantity	Pack Type	Product Code	Phillips Driver	Notes
M6.0 - 24 x 16	CL3+, W	1000	Bulk	SUFF3600162	<b>No. 2</b>	

## vortex™stud

*Ultra flat head for fastening thin metal studs where a very low profile head is required*



Product Description	Design Features	Pack Quantity	Pack Type	Product Code	Phillips Driver	Notes
<b>M4.2</b> - 18 x 12	CL3+,W	1000	Bulk	SUFC3420122	<b>No. 2</b>	
	Zn	1000	Bulk	SUFCZ420122		
<b>M5.4</b> - 16 x 16	CL3+,W	1000	Bulk	SUFC3540162		
			Bulk			



**UNIVERSAL SCREWS ENGINEERED FOR FIBRE BOARD APPLICATIONS**



**vortex™ fibre**

**COUNTERSUNK RIBBED HEAD (FOR 6-12mm SHEETING)**

*For fastening non-compressed fibre cement boards to timber & steel up to 1.6mm thick*

Product Description	Design Features	Pack Quantity	Pack Type	Product Code	Square Driver Bit	Notes
M5 - 14 x 20	CL3+,W	1000	Bulk	SURC3500202	<b>No. 2</b>	
	CL3+,W	100	Trade	SURC3500208		
	Zn	1000	Bulk	SURCZ500202		
M5 - 14 x 30	CL3+,W	1000	Bulk	SURC3500302		
	CL3+,W	100	Trade	SURC3500308		
	Zn	1000	Bulk	SURCZ500302		



**vortex™ fibre**

**BUGLE HEAD (FOR 4.5mm SHEETING)**

*For fastening non-compressed fibre cement boards to timber & steel up to 1.6mm thick*

Product Description	Design Features	Pack Quantity	Pack Type	Product Code	Phillips Driver	Notes
M5 - 14 x 20	CL3+,W	1000	Bulk	SUUC3500202	<b>No. 2</b>	
M5 - 14 x 20	Zn	1000	Bulk	SUUCZ500202		



**vortex™ deck**

**316 SERIES (A4) - DECKING SCREW**

**SELF EMBEDDING BULLET HEAD - SQUARE DRIVE - 316 SERIES (A4) STAINLESS STEEL**

*For one step fastening of timber decking boards to timber in highly corrosive areas.*

Product Description	Design Features	Pack Quantity	Pack Type	Product Code	Square Driver Bit	Notes
<b>10g</b> -11 x 50	SS 316	500	Bulk	SMQC6500502	<b>No. 2</b>	
	SS 316	100	Trade	SMQC6500508		
<b>10g</b> -11 x 50	SS 316	500	Bulk	SMQC6500652		
	SS 316	100	Trade	SMQC6500658		

**INNOVATIVE CYCLONE FASTENER SOLUTIONS**

**vortex cyclone™**



- Universal Cyclone Assembly
- Suitable for most common roofing profiles
- Suitable for timber, steel and thin metal battens
- Effective even if not drilled in dead straight
- Unique shock absorbing feature allows roofing to move while remaining water tight.
- Self aligning
- Complies with AS3566 -2002
- NT BAC Deemed to Comply
- Lo-Hi-Lo Tested & Certified
- Extensively tested

**Proven in the most extreme conditions**

Fully watertight with 4 Sealing Points

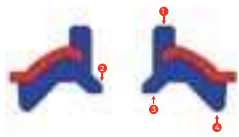



## HEX HEAD - WITHOUT SEAL FULL THREAD

*For general fastening to metal where a water tight seal is not necessary*



Product Description	Design Features	Pack Quantity	Pack Type	Product Code	Hexagonal Driver	Notes
<b>8g</b> - 18 x 12	Zn	1000	Bulk	SMHCZ080122	<b>1/4</b>	
	CL4+, W	1000	Bulk	SMHC4080122		
	B8(CAT5), W	1000	Bulk	SMHC8080122		
<b>8g</b> - 18 x 20	Zn	1000	Bulk	SMHCZ080202	<b>1/4</b>	
<b>10g</b> - 16 x 16	Zn	1000	Bulk	SMHCZ100162	<b>5/16</b>	
	Zn	100	Trade	SMHCZ100168		
	CL2+	1000	Bulk	SMHC2100162		
	CL3+,W	1000	Bulk	SMHC3100162		
	CL4+, W	1000	Bulk	SMHC4100162		
	CL4+, W	100	Trade	SMHC4100168		
	B8(Cat 5)	1000	Bulk	SMHC8100162		
	B8(Cat 5)	100	Trade	SMHC8100168		
<b>10g</b> - 24 x 16	Zn	1000	Bulk	SMHFZ100162		
	Zn	1000	Bulk	SMHFZ100162		
	CL4+, W	1000	Bulk	SMHF4100162		
<b>10g</b> - 16 x 25	Zn	1000	Bulk	SMHCZ100252		
	CL4+, W	1000	Bulk	SMHC4100252		
	CL4+, W	100	Trade	SMHC4100258		
<b>10g</b> - 24 x 25	Zn	1000	Bulk	SMHFZ100252		
	Zn	100	Trade	SMHFZ100258		
	CL4+, W	1000	Bulk	SMHF4100258		
<b>12g</b> - 14 x 20	Zn	1000	Bulk	SMHCZ120202	<b>5/16</b>	
	Zn	100	Trade	SMHCZ120208		
	CL2+	1000	Bulk	SMHC2120208		
	CL4+, W	500	Bulk	SMHC4120202		
	CL4+, W	100	Trade	SMHC4120208		
	B8(Cat 5)	500	Bulk	SMHC8120202		
	B8(Cat 5)	100	Trade	SMHC8120208		
<b>12g</b> - 24 x 20	Zn	1000	Bulk	SMHFZ120202		
	CL4+, W	1000	Bulk	SMHF4120202		
	CL4+, W	100	Trade	SMHF4120208		
<b>12g</b> - 24 x 25	Zn	1000	Bulk	SMHFZ120252		
<b>12g</b> - 24 x 30	CL4+, W	1000	Bulk	SMHF4120302		
<b>12g</b> - 14 x 30	CL4+, W	500	Bulk	SMHC4120302		
	CL4+, W	100	Trade	SMHC4120308		
	B8(CAT5), W	500	Bulk	SMHC8120302		
	B8(CAT5), W	100	Trade	SMHC8120308		





**HEX HEAD - WITHOUT SEAL  
FULL THREAD**

*For general fastening to metal where a  
water tight seal is not necessary*

Product Description	Design Features	Pack Quantity	Pack Type	Product Code	Hexagonal Driver	Notes
<b>14g</b> - 20 x 22	Zn	2000	Bulk	SMHCZ140222	<b>3/8</b>	
	CL4+, W	500	Bulk	SMHC4140222		
	CL4+, W	100	Trade	SMHC4140228		
	B8(CAT5), W	500	Bulk	SMHC8140222		
		100	Trade	SMHC8140228		
	B8(CAT5), W	500	Bulk	SMHC4140202		
<b>14g</b> - 10 x 20	CL4+, W	100	Trade	SMHC4140208		
	CL4+, W	500	Bulk	SMHCZ140252		
<b>14g</b> - 10 x 25	Zn	500	Bulk	SMHC4140252		
	CL4+, W	100	Trade	SMHC4140258		
	CL4+, W	500	Bulk	SMHC8140252		
	B8(CAT5), W	100	Trade	SMHC8140258		
	B8(CAT5), W	1000	Bulk	SMHF4140452		
<b>14g</b> - 20 x 45	CL4+, W	100	Trade	SMHF4140458		
	CL4+, W	1000	Bulk	SMHF8140452		
	B8(CAT5), W	100	Trade	SMHF8140458		
	B8(CAT5), W					

## Colours to match COLORBOND® Steel

This new colour range is the result of extensive market research by BlueScope Steel and reflects the latest market trends dictated by architects, building designers and builders in Australia. The following list contains the 20 fashionable colours in the COLORBOND® XRW product range.

Painted heads for all screws are available in the following colours or to your requirements. Other colours also available.

<b>SM</b> Surfmist™	<b>PE</b> Pale Eucalypt™
<b>WS</b> Windspray™	<b>CO</b> Cottage Green™
<b>WI</b> Wilderness™	<b>MN</b> Manor Red™
<b>HL</b> Headland™	<b>NS</b> Night Sky™
<b>DO</b> Deep Ocean™	<b>BD</b> Bushland™
<b>DU</b> Dune™	<b>PL</b> Plantation™
<b>CC</b> Classic Cream™	<b>IS</b> Ironstone™
<b>PA</b> Paperbank™	<b>SK</b> Sandbank™
<b>SH</b> Shale Grey™	<b>BI</b> Blue Ridge™
<b>WG</b> Woodland Grey™	<b>JA</b> Jasper™
<b>SS</b> Evening Haze™	<b>LO</b> Loft™

### PRODUCT CODES FOR PAINTED HEADS

For painted head codes, the two letter colour codes replace the 6th & 7th characters in the Product Code.

eg. for Surfmist™ 8-18 x 12  
the correct code is:  
SMHC3SM0121.

\*™ Colour names are trademarks of BlueScope Steel Limited.

COLORBOND® is a registered trade mark of BlueScope Steel Limited.



## HEX HEAD - WITHOUT SEAL PART THREAD

*For general fastening to metal where a water tight seal is not necessary*



Product Description	Design Features	Pack Quantity	Pack Type	Product Code	Hexagonal Driver	Notes
<b>12g</b> - 14 x 35	Zn,SP	1000	Bulk	SMHCZ120352	<b>5/16</b>	
	CL4+,W,SP	1000	Bulk	SMHC4120352		
<b>12g</b> - 14 x 45	Zn, SP	1000	Bulk	SMHCZ120452		
	CL4+,W,SP	1000	Bulk	SMHC4120452		
<b>12g</b> - 14 x 50	CL4+,W,SP	1000	Bulk	SMHC4120502		
<b>12g</b> - 14 x 55	CL4+,W,SP	1000	Bulk	SMHC4120552		
<b>12g</b> - 14 x 65	CL4+,W,SP	500	Bulk	SMHC4120652		
<b>12g</b> - 14 x 75	CL4+,W,SP	500	Bulk	SMHC4120752		
	B8(CAT5),W	500	Bulk	SMHC8120752		
<b>14g</b> - 10 x 42	CL4+,W,SP	1000	Bulk	SMHC4140422	<b>3/8</b>	
	CL4+,W,SP	100	Trade	SMHC4140428		
<b>14g</b> - 10 x 50	CL4+,W,SP	1000	Bulk	SMHC4140502		
	CL4+,W,SP	100	Trade	SMHC4140508		
<b>14g</b> - 10 x 65	CL4+,W,SP	500	Bulk	SMHC4140652		
	CL4+,W,SP	100	Trade	SMHC4140658		
	B8(CAT5),W,SP	500	Bulk	SMHC8140652		
	B8(CAT5),W,SP	100	Trade	SMHC8140658		
<b>14g</b> - 20 x 65	CL4+,W,SP	500	Bulk	SMHF4140652		
	CL4+,W,SP	100	Trade	SMHF4140658		
	B8(Cat 5),W,SP	500	Bulk	SMHF8140652		
	B8(Cat 5),W,SP	100	Trade	SMHF8140658		
<b>14g</b> - 10 x 75	CL4+,W,SP	500	Bulk	SMHC4140752		
	CL4+,W,SP	100	Trade	SMHC4140758		
	B8(Cat 5),W,SP	500	Bulk	SMHC8140752		
	B8(Cat 5),W,SP	100	Trade	SMHC8140758		
<b>14g</b> - 10 x 95	CL4+,W,SP	500	Bulk	SMHC4140952		
<b>14g</b> - 10 x 115	CL4+,W,SP	500	Bulk	SMHC4141152		
	CL4+,W,SP	100	Trade	SMHC4141158		
<b>14g</b> - 20 x 115	CL4+,W,SP	250	Bulk	SMHF4141152		
	B8(CAT5),W,SP	250	Bulk	SMHF8141152		
<b>14g</b> - 10 x 135	CL4+,W,SP	250	Bulk	SMHC4141352		
<b>14g</b> - 20 x 135	CL4+,W,SP	250	Bulk	SMHF4141352		
<b>14g</b> - 10 x 150	CL4+,W,SP	250	Bulk	SMHC4141502		
<b>14g</b> - 20 x 150	CL4+,W,SP	250	Bulk	SMHF4141502		
<b>14g</b> - 10 x 175	CL4+,W,SP	250	Bulk	SMHC4141752		
<b>14g</b> - 20 x 175	CL4+,W,SP	200	Bulk	SMHF4141752		
<b>14g</b> - 10 x 200	CL4+,W,SP	250	Bulk	SMHC4142002		
<b>14g</b> - 20 x 200	CL4+,W,SP	200	Bulk	SMHF4142002		





**HEX HEAD - WITH SEAL  
FULL THREAD**

*For general fastening to metal where a  
water tight seal is required*

Product Description	Design Features	Pack Quantity	Pack Type	Product Code	Hexagonal Driver	Notes
<b>8g - 18 x 12</b>	CL4+, W	1000	Bulk	SMHC4080121	<b>1/4</b>	
	B8(CAT5), W	1000	Bulk	SMHC8080121		
<b>10g - 16 x 16</b>	CL4+, W	1000	Bulk	SMHC4100161	<b>5/16</b>	
	CL4+, W	100	Trade	SMHC4100167		
		1000	Bulk	SMHC8100161		
	B8(CAT5), W	100	Trade	SMHC8100167		
	B8(CAT5), W	1000	Bulk	SMHC4100251		
<b>10g - 16 x 25</b>	CL4+, W	100	Trade	SMHC4100257		
	CL4+, W	500	Bulk	SMHC4120201		
<b>12g - 14 x 20</b>	CL4+, W	100	Trade	SMHC4120207	<b>5/16</b>	
	CL4+, W	500	Bulk	SMHC8120201		
	B8(CAT5), W	100	Trade	SMHC8120207		
	B8(CAT5), W	500	Bulk	SMHF4120201		
<b>12g - 24 x 20</b>	CL4+, W	100	Trade	SMHF4120207		
	CL4+, W	1000	Bulk	SMHC4120301		
<b>12g - 14 x 30</b>	CL4+, W	100	Trade	SMHC4120307		
	CL4+, W	1000	Bulk	SMHC8120301		
	B8(CAT5), W	100	Trade	SMHC8120307		
	B8(CAT5), W	1000	Bulk	SMHF4120301		
<b>12g - 24 x 30</b>	CL4+, W	100	Trade	SMHF4120307		
	CL4+, W	500	Bulk	SMHC4140201		
<b>14g - 10 x 20</b>	CL4+, W	100	Trade	SMHC4140207	<b>3/8</b>	
	CL4+, W	500	Bulk	SMHC4140221		
<b>14g - 20 x 22</b>	CL4+, W	100	Trade	SMHC4140227		
	CL4+, W	500	Bulk	SMHC8140221		
	B8(CAT5), W	100	Trade	SMHC8140227		
	B8(CAT5), W	500	Bulk	SMHC4140251		
<b>14g - 10 x 25</b>	CL4+, W	100	Trade	SMHC4140257		
	CL4+, W	500	Bulk			
	B8(CAT5), W	100	Trade	SMHC8140251		
	B8(CAT5), W	1000	Bulk	SMHC8140257		
	CL4+, W	1000	Bulk			
<b>14g - 20 x 45</b>	B8(CAT5), W			SMHF4140451		
				SMHF8140451		



## HEX HEAD - WITH SEAL PART THREAD

*For general fastening to metal where a water tight seal is required*



Product Description	Design Features	Pack Quantity	Pack Type	Product Code	Hexagonal Driver Notes
<b>12g</b> - 14 x 35	CL4+, W	1000	Bulk	SMHC4120351	<b>5/16</b>
<b>12g</b> - 14 x 45	CL4+,W,SP	1000	Bulk	SMHC4120451	
<b>12g</b> - 14 x 55	CL4+,W,SP	1000	Bulk	SMHC4120551	
<b>12g</b> - 14 x 65	CL4+,W,SP	500	Bulk	SMHC4120651	
<b>12g</b> - 14 x 75	CL4+,W,SP	500	Bulk	SMHC4120751	
	B8(CAT5), W	500	Bulk	SMHC8120751	
<b>14g</b> - 10 x 42	CL4+,W,SP	1000	Bulk	SMHC4140421	<b>3/8</b>
	CL4+,W,SP	100	Trade	SMHC4140427	
<b>14g</b> - 10 x 50	CL4+,W,SP	1000	Bulk	SMHC4140501	
	CL4+,W,SP	100	Trade	SMHC4140507	
<b>14g</b> - 10 x 65	CL4+,W,SP	500	Bulk	SMHC4140651	
	CL4+,W,SP	100	Trade	SMHC4140657	
	B8(CAT5),W,SP	500	Bulk	SMHC8140651	
	B8,W,SP	100	Trade	SMHC8140657	
<b>14g</b> - 10 x 75	CL4+,W,SP	500	Bulk	SMHC4140751	
	CL4+,W,SP	100	Trade	SMHC4140757	
	B8(CAT5),W,SP	500	Bulk	SMHC8140751	
	B8(CAT5),W,SP	100	Trade	SMHC8140757	
	CL4+,W,SP	500	Bulk	SMHC4140951	
<b>14g</b> - 10 x 95	CL4+,W,SP	100	Trade	SMHC4140957	
	B8(CAT5),W	500	Bulk	SMHC8140951	
	B8(CAT5),W	100	Trade	SMHC8140957	
	CL4+,W,SP	250	Bulk	SMHC4141151	
<b>14g</b> - 10 x 115	CL4+,W,SP	250	Bulk	SMHF4141151	
<b>14g</b> - 20 x 115	B8(CAT5),W,SP	250	Bulk	SMHF8141151	
	CL4+,W,SP	250	Bulk	SMHC4141351	
<b>14g</b> - 10 x 135	CL4+,W,SP	250	Bulk	SMHF4141351	
<b>14g</b> - 20 x 135	CL4+,W,SP	250	Bulk	SMHC4141501	
<b>14g</b> - 10 x 150	CL4+,W,SP	250	Bulk	SMHF4141501	
<b>14g</b> - 20 x 150	CL4+,W,SP	250	Bulk	SMHC4141751	
<b>14g</b> - 10 x 175	CL4+,W,SP	250	Bulk	SMHF4141751	
<b>14g</b> - 20 x 175	CL4+,W,SP	250	Bulk	SMHC4142001	<b>3/8</b>
<b>14g</b> - 10 x 200	CL4+,W,SP	250	Bulk	SMHF4142001	
<b>14g</b> - 20 x 200					



## TOPGRIP™ - WITH SEAL

*For fastening the crest of roof sheeting to metal where a water tight seal is required*

Product Description	Design Features	Pack Quantity	Pack Type	Product Code	Hexagonal Driver
<b>12g</b> - 14 x 35	CL4+,TG,W	1000	Bulk	SMHT4120351	<b>5/16</b>
	CL4+,TG,W	100	Trade	SMHT4120357	
	B8(CAT5),TG,W	1000	Bulk	SMHT8120351	
	B8(CAT5),TG,W	100	Trade	SMHT8120357	
<b>12g</b> - 14 x 45		1000	Bulk	SMHT4120451	
	CL4+,TG,W,SP	100	Trade	SMHT4120457	
	CL4+,TG,W,SP		Bulk	SMHT8120451	
	B8(CAT5),TG,W,SP	1000	Trade	SMHT8120457	
	B8(CAT5),TG,W,SP	100	Bulk	SMHT4120551	
<b>12g</b> - 14 x 55	CL4+,TG,W,SP	1000	Trade	SMHT4120557	
	CL4+,TG,W,SP	100	Bulk	SMHT8120551	
	B8(CAT5),TG,W,SP	1000	Trade	SMHT8120557	
	B8(CAT5),TG,W,SP	100	Bulk	SMHT4120681	
<b>12g</b> - 14 x 68	CL4+,TG,W,SP	1000	Trade	SMHT4120687	
	CL4+,TG,W,SP	100	Bulk	SMHT8120681	
	B8(CAT5),TG,W,SP	1000	Bulk	SMHT4120801	
<b>12g</b> - 14 x 80	CL4+,TG,W,SP	1000	Trade	SMHT4120807	
	CL4+,TG,W,SP	100		SMHT8120801	
	B8(CAT5),TG,W	1000	Bulk		
	B8(CAT5),TG,W	100	Trade	SMHT8120807	



## vortexroof™

## UNIVERSAL ROOFING SCREW FOR TIMBER OR METAL

*For fastening the crest of roof sheeting to metal battens, steel purlins and timber*

Product Description	Design Features	Pack Quantity	Pack Type	Product Code	Hexagonal Driver	Notes
<b>M6.2</b> - 13 x 50	CL4+, TG, W	1000	Bulk	SUHT4620501	<b>5/16</b>	
	CL4+, TG, W	100	Trade	SUHT4620507		
	B8(CAT5), TG, W	1000	Bulk	SUHT8620501		
	B8(CAT5), TG, W	100	Trade	SUHT8620507		
<b>M6.2</b> - 13 x 65	CL4+, TG, W	500	Bulk	SUHT4620651		
	CL4+, TG, W	100	Trade	SUHT4620657		
	B8(CAT5), TG, W	1000	Bulk	SUHT8620651		
	B8(CAT5), TG, W	100	Trade	SUHT8620657		



## vortex<sup>™</sup>corri

### UNIVERSAL ROOFING SCREW FOR METAL

For fastening the crests of corrugated roofing profiles to metal battens or steel up to 1.5mm thick.



Product Description	Design Features	Pack Quantity	Pack Type	Product Code	Hexagonal Notes Driver
<b>M6.2</b> - 13 x 42	CL4+, TG, W	1000	Bulk	SUHT4620421	<b>5/16</b>
	CL4+, TG, W	100	Trade	SUHT4620427	
	B8(CAT5), TG, W	1000	Bulk	SUHT8620421	
	B8(CAT5), TG, W	100	Trade	SUHT8620427	

## vortex<sup>™</sup>shed

### A 14g SELF DRILLING SCREW WITH A 12g HEX HEAD

For heavy duty framing applications



Product Description	Design Features	Pack Quantity	Pack Type	Product Code	Hexagonal Notes Driver
<b>M6.2</b> - 13 x 22	CL4+, W	500	Bulk	SUHC4620222	<b>5/16</b>
	CL4+, W	100	Trade	SUHC8620228	
	B8(CAT5), W	500	Bulk	SUHC8620222	
	B8(CAT5), W	100	Trade	SUHC8620228	

## vortex<sup>™</sup>battenfix

Universal Screw for fastening thin metal battens and ceiling battens to timber or steel



Product Description	Design Features	Pack Quantity	Pack Type	Product Code	Hexagonal Notes Driver
<b>12g</b> - 11 x 40	CL3+, W	1000	Bulk	SUHC3120402	<b>5/16</b>
	CL3+, W	100	Trade	SUHC3120408	

## vortex<sup>™</sup>cyclone

### UNIVERSAL CYCLONE ASSEMBLIES FOR STEEL & TIMBER

For pan fastening of square rib profiles to timber, thin metal battens and steel purlins.



Product Description	Design Features	Pack Quantity	Pack Type	Product Code	Hexagonal Notes Driver
<b>M6.2</b> - 13 x 25	CL4+, W	250	Bulk	SUHC462025D	<b>5/16</b>
	B8(CAT5), W	250	Bulk	SUHC862025D	



**vortex<sup>TM</sup> cyclone**  
UNIVERSAL CYCLONE ASSEMBLIES  
FOR STEEL & TIMBER

*For fastening corrugated and square rib profiles to timber, thin metal battens and steel purlins*

Product Description	Design Features	Pack Quantity	Pack Type	Product Code	Hexagonal Notes Driver
M6.2 - 13 x 25	CL4+, W	250	Bulk	SUHC462025D	<b>5/16</b>
	B8(CAT5), W	250	Bulk	SUHC862025D	
M6.2 - 13 x 55	CL4+, TG, W	250	Bulk	SUHC462055D	<b>3/8</b>
	B8(CAT5), TG, W	250	Bulk	SUHC862055D	
M6.2 - 13 x 65	CL4+, TG, W	250	Bulk	SUHC462065D	
	B8(CAT5), TG, W	250	Bulk	SUHC862065D	
M6.2 - 13 x 95	CL4+, TG, W	250	Bulk	SUHC462095D	



**CYCLONE ASSEMBLIES - BRA**  
**BREMICK ROOFING ASSEMBLY - FULL THREAD**

*For fastening the crest of corrugated and square rib profiles to thin metal battens and steel purlins*

Product Description	Design Features	Pack Quantity	Pack Type	Product Code	Hexagonal Notes Driver
<b>14g</b> - 10 x 50	CL4+, W	250	Bulk	SMHC414050D	<b>3/8</b>
	B8(CAT5), W	250	Bulk	SUHC814050D	
<b>14g</b> - 10 x 65	CL4+, W	250	Bulk	SMHC414065D	
	B8(CAT5), W	250	Bulk	SMHC814065D	



## CYCLONE ASSEMBLIES - BRA BREMICK ROOFING ASSEMBLY - PART THREAD

*For fastening the crest of corrugated and square rib profiles to thin metal battens and steel purlins*



Product Description	Design Features	Pack Quantity	Pack Type	Product Code	Hexagonal Driver	Notes
<b>14g</b>	- 10 x 75 CL4+,W, SP	250	Bulk	SMHC414075B	<b>3/8</b>	
<b>14g</b>	- 10 x 95 CL4+,W, SP	250	Bulk	SMHC414095B		
<b>14g</b>	- 10 x 115 CL4+,W, SP	250	Bulk	SMHC414115B		
<b>14g</b>	- 10 x 135 CL4+,W, SP	200	Bulk	SMHC414135B		
<b>14g</b>	- 10 x 175 CL4+,W, SP	200	Bulk	SMHC414175B		

## CYCLONE ASSEMBLIES – BRA STAINLESS STEEL 304 SERIES (A2) - HEXAGONAL BREMICK ROOFING ASSEMBLY - FULL THREAD

*For fastening the crest of corrugated and square rib profiles to thin metal battens and steel purlins*



Product Description	Design Features	Pack Quantity	Pack Type	Product Code	Hexagonal Driver	Notes
<b>14g</b>	- 10 x 50 SS	250	Bulk	SMHC614050D	<b>3/8</b>	
<b>14g</b>	- 10 x 65 SS	250	Bulk	SMHC614065D		





### CYCLONE ASSEMBLIES - CUSTOM ORB®

*For fastening the crest of  
corrugated profiles to steel*

Product Description	Design Features	Pack Quantity	Pack Type	Product Code	Hexagonal Driver	Notes
14g - 10 x 42	CL4+,W,SP	200	Bulk	SMHC414042C	3/8	



### CYCLONE ASSEMBLIES - TRIMDEK® / SPANDEK®

*For fastening the crest of square rib profiles to steel*

Product Description	Design Features	Pack Quantity	Pack Type	Product Code	Hexagonal Driver	Notes
14g - 10 x 50	CL4+,W,SP	200	Bulk	SMHC414050T	3/8	



### CYCLONE ASSEMBLIES - KLIPOK®

*For fastening the crest of secret  
clip profiles to steel*

Product Description	Design Features	Pack Quantity	Pack Type	Product Code	Hexagonal Driver	Notes
14g - 10 x 65	CL4+,W,SP	200	Bulk	SMHC414065K	3/8	
- 10 x 75	CL4+,W,SP	200	Bulk	SMHC414075K		



### CYCLONE ASSEMBLIES - KINGKLIP®

*For fastening the crest of secret  
clip profiles to steel*

Product Description	Design Features	Pack Quantity	Pack Type	Product Code	Hexagonal Driver	Notes
14g - 14 x 65	CL4+,W,SP	200	Bulk	SMHC414065F	3/8	
14g - 14 x 75	CL4+,W,SP	200	Bulk	SMHC414075F		



### POLYCARBONATE ROOFING ASSEMBLIES

*For fastening the crest of polycarbonate profiles to steel*

Product Description	Design Features	Pack Quantity	Pack Type	Product Code	Hexagonal Driver	Notes
12g - 14 x 35	CL4+,W	500	Bulk	SMHC412035P	5/16	
12g - 14 x 45	CL4+,W,SP	500	Bulk	SMHC412045P		

CUSTOM ORB®, TRIMDEK®, SPANDEK® and KLIPOK® are registered trade marks of BlueScope Steel Limited.





### vortex<sup>poly</sup>

#### UNIVERSAL POLYCARBONATE ASSEMBLY FOR TIMBER OR STEEL

*For fastening the crests of Polycarbonate roof sheeting to timber battens or steel. With cutting fins for automatic forming of expansion hole.*



Product Description	Design Features	Pack Quantity	Pack Type	Product Code	Hexagonal Notes Driver
<b>M6.2</b> -13 x 50	CL4+, W	250	Bulk	SUHT462050P	<b>5/16</b>
		100	Trade	TUHT462050P	
<b>M6.2</b> -13 x 65	CL4+, W	250	Bulk	SUHT462065P	<b>5/16</b>

### vortex<sup>fibreglass</sup>

#### METAL DRILLING FIBREGLASS ASSEMBLY FOR STEEL

*For fastening the crests of Fibreglass roof sheeting to steel purlins. With cutting fins for automatic forming of expansion hole.*

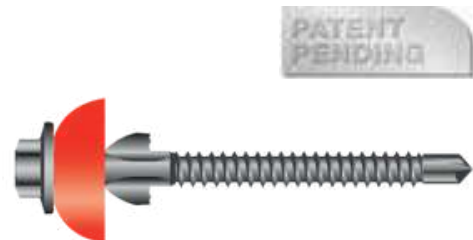

Product Description	Design Features	Pack Quantity	Pack Type	Product Code	Hexagonal Notes Driver
<b>12g</b> - 13 x 65	CL4+, W	250	Bulk	SMHC412065G	<b>5/16</b>
		100	Trade	TMHC412065G	

#### RIDGE ASSEMBLY

##### HEX HEAD WASHER WITH 16mm ALUMINIUM 5251 / EPDM BONDED WASHER

*For fastening the crests of roof sheeting to steel purlins*



Product Description	Design Features	Pack Quantity	Pack Type	Product Code	Hexagonal Notes Driver
<b>14g</b> -10 x 42	CL4+,W,SP	1000	Bulk	SMHC4140424	<b>3/8</b>
<b>14g</b> -10 x 50	CL4+,W,SP	1000	Bulk	SMHC4140504	

#### RIDGE ASSEMBLY

##### HEX HEAD WASHER WITH 19mm ALUMINIUM 5251 / EPDM BONDED WASHER

*For fastening metal ridges and flashings to steel*

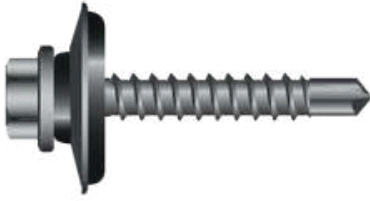

Product Description	Design Features	Pack Quantity	Pack Type	Product Code	Hexagonal Notes Driver
<b>14g</b> -10 x 42	CL4+,W,SP	500	Bulk	SMHC4140425	<b>3/8</b>
<b>14g</b> -10 x 50	CL4+,W,SP	500	Bulk	SMHC4140505	

**RIDGE ASSEMBLY**

**HEX HEAD WASHER WITH 25mm  
ALUMINIUM 5251 / EPDM BONDED WASHER**

*For fastening metal ridges of flashings to steel*

Product Description	Design Features	Pack Quantity	Pack Type	Product Code	Hexagonal Notes Driver
<b>14g</b> -10 x 42	CL4+,W,SP	500	Bulk	SMHC4140426	<b>3/8</b>
<b>14g</b> -10 x 50	CL4+,W,SP	250	Bulk	SMHC4140506	
<b>14g</b> -10 x 65	CL4+,W,SP	250	Bulk	SMHC4140656	

**DEEP DRILLER**

**HEX HEAD - WITHOUT SEAL**

*For fastening steel up to 12.5mm thick*

Product Description	Design Features	Pack Quantity	Pack Type	Product Code	Hexagonal Notes Driver
<b>12g</b> - 24 x 32	CL4+, W	500	Bulk	S5HC4120322	<b>5/16</b>
	CL4+, W	100	Trade	S5HC4120328	
	B8(CAT 5), W	500	Bulk	S5HC8120322	
	B8(CAT 5), W	100	Trade	S5HC8120328	
<b>12g</b> - 24 x 50	CL4+, W	1000	Bulk	S5HC4120502	
	CL4+, W	100	Trade	S5HC4120508	
	B8(CAT 5), W	1000	Bulk	S5HC8120502	
	B8(CAT 5), W	100	Trade	S5HC8120508	
	CL4+, W	1000	Bulk	S5HC4120652	
<b>12g</b> - 24 x 65	B8(CAT 5), W	1000	Bulk	S5HC8120652	
	CL4+W	500	Bulk	S5HC4140352	
<b>14g</b> - 24 x 35	CL4+, W	500	Bulk	S5HC4140652	<b>3/8</b>
<b>14g</b> - 24 x 65	CL4+, W	500	Bulk	S5HC4140952	
<b>14g</b> - 24 x 95	CL4+, W	250	Bulk	S5HC4141152	
<b>14g</b> - 24 x 115	CL4+, W	250	Bulk	S5HC4141502	
<b>14g</b> - 24 x 150	CL4+, W	200	Bulk	S5HC4141752	
<b>14g</b> - 24 x 175					



## DEEP DRILLER

### HEX HEAD - WITH SEAL

*For fastening steel up to 12.5mm thick where a water tight seal is required*



Product Description	Design Features	Pack Quantity	Pack Type	Product Code	Hexagonal Driver	Notes
<b>12g</b> - 24 x 32	CL4+, W	500	Bulk	S5HC4120321	<b>5/16</b>	
	CL4+, W	100	Trade			
	B8(CAT 5), W	500	Bulk	S5HC4120327		
	B8(CAT 5), W	100	Trade	S5HC8120321		
<b>12g</b> - 24 x 50				S5HC8120327		
	CL4+, W	1000	Bulk			
	CL4+, W	100	Trade	S5HC4120501		
	B8(CAT 5), W	1000	Bulk	S5HC4120507		
	B8(CAT 5), W	100	Trade	S5HC8120501		
<b>12g</b> - 24 x 65				S5HC8120507		
	B8(CAT 5), W	1000	Bulk	S5HC4120651		
	CL4+W	500	Bulk	S5HC8120651		
<b>14g</b> - 24 x 35	CL4+, W	500	Bulk	S5HC4140351	<b>3/8</b>	
<b>14g</b> - 24 x 65	CL4+, W	500	Bulk	S5HC4140651		
<b>14g</b> - 24 x 95	CL4+, W	250	Bulk	S5HC4140951		
<b>14g</b> - 24 x 115	CL4+, W	250	Bulk	S5HC4141151		
<b>14g</b> - 24 x 150	CL4+, W	200	Bulk	S5HC4141501		
<b>14g</b> - 24 x 175				S5HC4141751		

## DEEP DRILLER

### WAFER HEAD - WITHOUT SEAL

*For fastening steel up to 12.5mm thick where a flat head is required*



Product Description	Design Features	Pack Quantity	Pack Type	Product Code	Phillips Driver	Notes
<b>12g</b> - 24 x 32	CL3+, W	500	Bulk	S5WC3120322	<b>No. 3</b>	
	CL4+, W	500	Bulk	S5WC4120322		
	B8(CAT5), W	500	Bulk	S5WC8120322		

## vortex<sup>TM</sup>mini

### RAISED PHILLIPS HEAD CL3

*For fastening the valley of mini-corrugated sheeting to steel or timber*



Product Description	Design Features	Pack Quantity	Pack Type	Product Code	Phillips Driver	Notes
<b>10g</b> - 14 x 20	CL3+, W	1000	Bulk	SUMC3100202	<b>No. 2</b>	
	CL3+, W	1000	Bulk	SUMC3100202		
<b>10g</b> - 14 x 30	CL3+, W	1000	Bulk	SUMC3100302		
	CL3+, W	100	Trade	SUMC3100308		



**vortexclad**

*For fastening the valley of steel walling  
profi les to steel or timber - Without Seal*

Product Description	Design Features	Pack Quantity	Pack Type	Product Code	Hexagonal Notes Driver
M5.4 - 14 x 25	CL4, W	500	Bulk	SUHC4540252	5/16
	B8(CAT5),W	500	Bulk	SUHC8540252	



**vortexclad**

*For fastening the valley of steel walling  
profi les to steel or timber - With Seal*

Product Description	Design Features	Pack Quantity	Pack Type	Product Code	Hexagonal Notes Driver
M5.4 - 14 x 25	CL4, W	500	Bulk	SUHC4540251	5/16
	B8(CAT5),W	500	Bulk	SUHC8540251	



**vortexclad**

*For fastening the valley of steel walling  
profi les to steel or timber - Without Seal*

Product Description	Design Features	Pack Quantity	Pack Type	Product Code	Hexagonal Notes Driver
M6.2 - 13 x 25	CL4, W	500	Bulk	SUHC4620252	5/16
	B8(CAT5),W	500	Bulk	SUHC8620252	



**vortexclad**

*For fastening the valley of steel walling  
profi les to steel or timber - With Seal*

Product Description	Design Features	Pack Quantity	Pack Type	Product Code	Hexagonal Notes Driver
M6.2 - 13 x 25	CL4, W	500	Bulk	SUHC4620251	5/16
	B8(CAT5),W	500	Bulk	SUHC8620251	



**vortexstud**

*Ultra flat head for fastening thin metal studs  
where a very low Profile head is required*

Product Description	Design Features	Pack Quantity	Pack Type	Product Code	Phillips Driver	Notes
M4.2 - 18 x 12	CL3+, W	1000	Bulk	SUFC3420122	No. 2	
- 18 x 12	Zn	1000	Bulk	SUFCZ420122		
M5.4 - 16 x 16	CL3+, W	1000	Bulk	SUFC3540162		



## WAFER HEAD

*For fastening into metal where a flat head is required*



Product Description	Design Features	Pack Quantity	Pack Type	Product Code	Phillips Driver	Notes
<b>8g</b> - 18 x 12	Zn	1000	Bulk	SMWCZ080122	<b>No. 2</b>	
	Zn	100	Trade	SMWCZ080128		
<b>10g</b> - 16 x 16	Zn	1000	Bulk	SMWCZ100162	<b>No. 2</b>	
	Zn	100	Trade	SMWCZ100168		
	CL3+W	1000	Bulk	SMWC3100162		
	CL3+W	100	Trade			
	CL4+,W	1000	Bulk	SMWC3100168		
	CL4+,W	100	Trade	SMWC4100162		
<b>10g</b> - 24 x 16	Zn	1000	Bulk	SMWC4100168		
	Zn	100	Trade	SMWFZ100162		
	CL3+,W	1000	Bulk	SMWFZ100168		
	CL3+,W	100	Trade	SMWF3100162		
	CL4+,W	1000	Bulk	SMWF3100168		
	CL4+,W	100	Trade	SMWF4100162		
<b>10g</b> - 16 x 22	Zn	1000	Bulk	SMWF4100168		
	Zn	100	Trade	SMWCZ100222		
	CL3+,W	1000	Bulk	SMWCZ100228		
	CL3+,W	100	Trade	SMWC3100222		
	CL4+,W	1000	Bulk	SMWC3100228		
	CL4+,W	100	Trade	SMWC4100222		
<b>10g</b> - 24 x 22	Zn	1000	Bulk	SMWC4100228		
	Zn	100	Trade	SMWFZ100222		
	CL3+	1000	Bulk	SMWFZ100228		
	CL3+	100	Trade	SMWF3100222		
	CL4+,W	1000	Bulk	SMWF3100228		
	CL4+,W	100	Trade	SMWF4100222		
<b>10g</b> - 16 x 30	CL3+,W	1000	Bulk	SMWF4100228		
	CL3+,W	100	Trade	SMWC3100302		
	CL4+,W	1000	Bulk	SMWC3100308		
	CL4+,W	100	Trade	SMWC4100302		
<b>10g</b> - 24 x 30	Zn	1000	Bulk	SMWC4100308		
	Zn	100	Trade	SMWFZ100302		
	CL3+,W	1000	Bulk	SMWFZ100308		
	CL4+,W	1000	Bulk	SMWF3100302		
	CL4+,W	100	Trade	SMWF4100302		
	CL3+,W	1000	Bulk	SMWF4100308		
<b>10g</b> - 24 x 40	CL4+,W	1000	Bulk	SMWF3100402		
	CL4+,W	100	Trade	SMWF4100402		
				SMWF4100408		



**BUTTON HEAD**

*For fastening into metal where a larger profile head is required*

Product Description	Design Features	Pack Quantity	Pack Type	Product Code	Phillips Driver	Notes
<b>8g</b> - 18 x 12	Zn	1000	Bulk	SMBCZ080122	<b>No. 2</b>	
	Zn	100	Trade	SMBCZ080128		
	CL3+	1000	Bulk	SMBC3080122		
<b>8g</b> - 18 x 16	Zn	1000	Bulk	SMBCZ080162		
	Zn	100	Trade	SMBCZ080168		
	CL3+,W	1000	Bulk	SMBC3080162		
<b>8g</b> - 18 x 20	Zn	1000	Bulk	SMBCZ080202		
	Zn	100	Trade	SMBCZ080208		
	CL3+,W	1000	Bulk	SMBC3080202		
<b>8g</b> - 18 x 25	Zn	1000	Bulk	SMBCZ080252		
	Zn	100	Trade	SMBCZ080258		
	CL3+,W	1000	Bulk	SMBC3080252		
<b>8g</b> - 18 x 32	Zn	1000	Bulk	SMBCZ080322		
	Zn	100	Trade	SMBCZ080328		
	CL3+,W	1000	Bulk	SMBC3080322		

**COUNTERSUNK HEAD****ZINC YELLOW**

*For fastening predrilled fixtures to metal where a flush finish is required*

Product Description	Design Features	Pack Quantity	Pack Type	Product Code	Phillips Driver	Notes
<b>6g</b> - 20 x 20	Zn	1000	Bulk	SMKCZ060202	<b>No.2</b>	
<b>6g</b> - 20 x 30	Zn	1000	Bulk	SMKCZ060302		
<b>6g</b> - 20 x 40	Zn	1000	Bulk	SMKCZ060402		
<b>6g</b> - 20 x 50	Zn	1000	Bulk	SMKCZ060502		
<b>8g</b> - 18 x 25	Zn	1000	Bulk	SMKCZ080252	<b>No.2</b>	
	Zn	100	Trade	SMKCZ080258		
<b>10g</b> - 24 x 25	Zn	1000	Bulk	SMKCZ100252	<b>No.2</b>	
<b>10g</b> - 24 x 30	Zn	1000	Bulk	SMKCZ100302		
	Zn	100	Trade	SMKCZ100308		
<b>10g</b> - 24 x 40	Zn	1000	Bulk	SMKCZ100402		
	Zn	100	Trade	SMKCZ100408		
<b>10g</b> - 24 x 50	Zn	500	Bulk	SMKCZ100502		
	Zn	100	Trade	SMKCZ100508		
<b>10g</b> - 24 x 65	Zn	500	Bulk	SMKCZ100652		



## COUNTERSUNK HEAD - EXTENDED POINT

### ZINC YELLOW

*For fastening timber fixtures onto plasterboard and steel*



Product Description	Design Features	Pack Quantity	Pack Type	Product Code	Phillips Driver	Notes
6g - 20 x 50	Zn	1000	Bulk	SXKCZ060502	No. 2	
6g - 20 x 65	Zn	500	Bulk	SXKCZ060652		

## COUNTERSUNK RIB HEAD

*For fastening sheeting / fibre cement where a self embedding head is required*



Product Description	Design Features	Pack Quantity	Pack Type	Product Code	Phillips Driver	Notes
8g - 18 x 20	Zn	1000	Bulk	SMRCZ080202	No.2	
	CL3+,W	1000	Bulk	SMRC3080202		
8g - 18 x 25	Zn	1000	Bulk	SMRCZ080252		
	CL3+,W	1000	Bulk	SMRC3080252		
8g - 18 x 30	Zn	1000	Bulk	SMRCZ080302		
	CL3+,W	1000	Bulk	SMRC3080302		

## PRODUCT FEATURE KEY

- W Zn** Covered by the Bremick Warranty
- CL3+** Zinc Yellow
- CL4+** Corrosion protection to AS3566 Class 3 plus - Armourcoat®
- TG SP** Corrosion protection to AS3566 Class 4 plus - Armourcoat® 4
- SS B8** Top Grip®
- (CAT 5)** Shank Protector®
- Stainless Steel
- Revolution B8 Corrosion Protection to AS 3566 Class 4
- Suitable for use in ISO 9223 Category 5 Corrosive Environments (Very Severe Marine / Very Severe Industrial)



Tested and Certified in accordance with the design of buildings in cyclonic areas to Building Codes of Australia BCA 2006 Volume One Specification B 1.2. (Lo – Hi – Lo Cyclic Test Method.)



Northern Territory Building Approval Committee (NT BAC) approved for use in cyclonic areas and listed in the NT BAC Deemed To Comply Manual (NT DTCM).



Patent Protected



Stainless Steel Self Drilling Screw with carbon steel drill point capable of drilling into metal, over coated with an anti cease zinc rich coating.

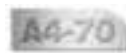

Manufactured from Stainless Steel



Grade  
A4 -70 (Stainless Steel Grade 316)  
A2 -70 (Stainless Steel Grade 304)



Patent Pending





### WING DRILLER - COUNTERSUNK RIB HEAD

*For fastening timber and composite boards to metal where a flush finish is required*

Product Description	Design Features	Pack Quantity	Pack Type	Product Code	Phillips Driver	Notes
6g - 20 x 50	Zn	1000	Bulk	SWRCZ060502	No. 2	
	Zn	100	Trade	SWRCZ060508		
	CL3+, W	1000	Bulk	SWRC3060502		
8g - 18 x 35	Zn	1000	Bulk	SWRCZ080352	No. 2	
	CL3+, W	1000	Bulk	SWRC3080352		
	CL3+, W	1000	Trade	SWRC3080358		
10g - 16 x 35	Zn	500	Bulk	SWRCZ100352	No. 2	
	Zn	100	Trade	SWRCZ100358		
	CL3+,W	500	Bulk	SWRC3100352		
10g - 16 x 40	Zn	500	Bulk	SWRCZ100402		
	CL3+, W	500	Bulk	SWRC3100402		
	CL3+, W	100	Trade	SWRC3100408		
10g - 16 x 45	Zn	500	Bulk	SWRCZ100452		
	Zn	100	Trade	SWRCZ100458		
	CL3+, W	500	Bulk	SWRC3100452		
	CL3+, W	100	Trade	SWRC3100458		
10g - 16 x 50	Zn	500	Bulk	SWRCZ100502		
	Zn	100	Trade	SWRCZ100508		
10g - 16 x 55	Zn	1000	Bulk	SWRCZ100552		
	Zn	100	Trade	SWRCZ100558		
	CL3+, W	1000	Bulk	SWRC3100552		
10g - 16 x 70	Zn	500	Bulk	SWRCZ100702		
	Zn	100	Trade	SWRCZ100708		
10g - 16 x 75	Zn	1000	Bulk	SWRCZ100752		
	Zn	100	Trade	SWRCZ100758		
	CL3+, W	1000	Bulk	SWRC3100752		
14g - 20 x 65	CL3+,W	500	Bulk	SWRC3140652	No. 3	



### WING DRILLER - COUNTERSUNK RIB HEAD

#### SQUARE DRIVE

*For fastening timber and composite boards to metal where a flush finish is required*

Product Description	Design Features	Pack Quantity	Pac Type	Product Code	Square Driver	Notes
14g - 20 x 65 -	CL4+, W	500		SWRC4140652	No. 3	
14g 20 x 75 -	CL4+, W	500	Typ	SWRC4140752		
14g 20 x 95 -	CL4+, W	250	Bulk	SWRC4140952		
14g 20 x 115	CL4+, W	250	Bulk	SWRC4141152		

Please Note: When moisture content on treated pine exceeds 10% use 12g screws minimum.

Bulk

**WING DRILLER - COUNTERSUNK HEAD  
ZINC YELLOW***For flush fastening timber materials to metal*

Product Description	Design Features	Pack Quantity	Pack Type	Product Code	Phillips Driver	Notes
14g - 20 x 50	Zn	500	Bulk	SWKCZ140502	<b>No. 3</b>	
14g - 20 x 60	Zn	500	Bulk	SWKCZ140602		

**WING DRILLER - SELF EMBEDDING HEAD  
FLOWER HEAD***For fastening rigid boards to steel*

Product Description	Design Features	Pack Quantity	Pack Type	Product Code	Phillips Driver	Notes
8g - 18 x 35	Zn	1000	Bulk	SWECZ080352	<b>No. 2</b>	
8g - 18 x 40	Zn	1000	Bulk	SWECZ080402		
10g - 24 x 30	Zn	1000	Bulk	SWECZ100302	<b>No. 2</b>	
10g - 16 x 40	Zn	500	Bulk	SWECZ100402		

**SELF EMBEDDING HEAD -  
EXTENDED POINT***For fastening rigid boards to metal up to 3mm thick*

Product Description	Design Features	Pack Quantity	Pack Type	Product Code	Phillips Driver	Notes
8g - 18 x 50	Zn	1000	Bulk	SXECZ080502	<b>No. 2</b>	

**SELF EMBEDDING HEAD  
ZINC YELLOW***For fastening rigid boards to steel*

Product Description	Design Features	Pack Quantity	Pack Type	Product Code	Phillips Driver	Notes
8g - 18 x 20	Zn	1000	Bulk	SMECZ080202	<b>No 2</b>	
8g - 18 x 25	Zn	1000	Bulk	SMECZ080252		
8g - 18 x 30	Zn	1000	Bulk	SMECZ080302	<b>No 2</b>	
10g - 24 x 25	Zn	1000	Bulk	SMECZ100252		



**PAN HEAD  
ZINC YELLOW**

*For fastening to steel where a rasied head is required*

Product Description	Design Features	Pack Quantity	Pack Type	Product Code	Phillips Driver	Notes
6g - 20 x 12	Zn	1000	Bulk	SMPCZ060122	No.2	
8g - 18 x 12	Zn	1000	Bulk	SMPCZ080122	No.2	
8g - 18 x 16	Zn	1000	Bulk	SMPCZ080162		
8g - 18 x 22	Zn	1000	Bulk	SMPCZ080222		



**BUGLE HEAD  
ZINC YELLOW**

*For fastening plasterboard to steel up to 2mm thick*

Product Description	Design Features	Pack Quantity	Pack Type	Product Code	Phillips Driver	Notes
6g - 18 x 25	Zn	1000	Bulk	SMUCZ060252	No.2	
	Zn	100	Trade	SMUCZ060258		
6g - 18 x 30	Zn	1000	Bulk	SMUCZ060302		
	Zn	100	Trade	SMUCZ060308		
6g - 18 x 40	Zn	1000	Bulk	SMUCZ060402		
	Zn	100	Trade	SMUCZ060408		
6g - 18 x 45	Zn	1000	Bulk	SMUCZ060452		
	Zn	100	Trade	SMUCZ060458		
6g - 18 x 60	Zn	1000	Bulk	SMUCZ080602		



**vortex<sup>TM</sup>truss**  
**HEX HEAD WITH TRILOBULAR SHANK**

*Thread with a cone point for heavy duty fastening through 6mm diameter pre-drilled holes in steel*

Product Description	Design Features	Pack Quantity	Pack Type	Product Code	Hexagonal Driver	Notes
17g - 13 x 18	CL2+	500	Bulk	SUHC2170182	3/8	
	CL4+, W	500	Bulk	SUHC4170182		



**vortex<sup>TM</sup>frame**

*Ultra fl at head with trilobular Vortex thread with a cone point for fastening light steel sections through 3 to 3.5mm diameter pre-drilled holes*

Product Description	Design Features	Pack Quantity	Pack Type	Product Code	Phillips Driver	Notes
M6.0 - 24 x 16	CL3+, W	1000	Bulk	SUFF3600162	No.2	



**vortex**<sup>TM</sup> stitch

*For heavy duty stitching of roofing and walling profiles to steel with sealing washer*



Product Description	Design Features	Pack Quantity	Pack Type	Product Code	Hexagonal Driver	Notes
M6.5 - 13 x 20	CL4+, W	500	Bulk	SUHC4650201	5/16	

**vortex**<sup>TM</sup> stud

*Ultra flat head for fastening thin metal studs where a very low profile head is required*



Product Description	Design Features	Pack Quantity	Pack Type	Product Code	Phillips Driver	Notes
M4.2 - 18 x 12	CL3+, W	1000	Bulk	SUFC3420122	No. 2	
- 18 x 12	Zn	1000	Bulk	SUFCZ420122		
M5.4 - 16 x 16	CL3+, W	1000	Bulk	SUFC3540162		

**vortex**<sup>TM</sup> fibre

**COUNTERSUNK RIBBED HEAD (FOR 6-12mm SHEETING)**

*For fastening non-compressed fibre cement boards to timber & steel up to 1.6mm thick*



Product Description	Design Features	Pack Quantity	Pack Type	Product Code	Square Driver	Notes
M5 - 14 x 20	CL3+, W	1000	Bulk	SURC3500202	No. 2	
	Zn	1000	Bulk	SURCZ500202		
M5 - 14 x 30	CL3+, W	1000	Bulk	SURC3500302		
	Zn	1000	Bulk	SURCZ500302		

**vortex**<sup>TM</sup> fibre

**BUGLE HEAD (FOR 4.5mm SHEETING)**

*For fastening non-compressed fibre cement boards to timber & steel up to 1.6mm thick*



Product Description	Design Features	Pack Quantity	Pack Type	Product Code	Phillips Driver	Notes
M5 - 14 x 20	CL3+, W	1000	Bulk	SUUC3500202	No. 2	
	Zn	1000	Bulk	SUUCZ500202		



**STITCH SCREWS - NEEDLE POINT  
HEX SLOTTED - WITHOUT SEAL**

*For general fastening to both timber and thin steel*

Product Description	Design Features	Pack Quantity	Pack Type	Product Code	Hexagonal Notes Driver
8g - 15 x 15	CL3+, W	1000	Bulk	SNSC3080152	1/4



**STITCH SCREWS - NEEDLE POINT  
HEX SLOTTED - WITH SEAL**

*For general fastening to both timber and thin steel  
where a water tight seal is required*

Product Description	Design Features	Pack Quantity	Pack Type	Product Code	Hexagonal Notes Driver
8g - 15 x 15	CL3+, W	1000	Bulk	SNSC3080151	1/4
	CL3+, W	100	Trade	SNSC3080157	



**STITCH SCREWS - NEEDLE POINT  
HEX SLOTTED WITH SERRATION  
UNDER HEAD - WITHOUT SEAL**

*For general fastening to both timber and thin steel*

Product Description	Design Features	Pack Quantity	Pack Type	Product Code	Hexagonal Notes Driver
8g - 15 x 15	CL3+, W	1000	Bulk	SNXC3080152	1/4



**STITCH SCREWS - NEEDLE POINT  
HEX HEAD - WITH SEAL**

*For general fastening to both timber and thin steel  
where a water tight seal is required*

Product Description	Design Features	Pack Quantity	Pack Type	Product Code	Hexagonal Notes Driver
10g - 12 x 20	CL3+, W	1000	Bulk	SNHC3100201	5/16



**STITCH SCREWS - NEEDLE POINT  
HEX HEAD - WITHOUT SEAL**

*For general fastening to both timber and thin steel*

Product Description	Design Features	Pack Quantity	Pack Type	Product Code	Hexagonal Notes Driver
10g - 12 x 20	CL3+, W	1000	Bulk	SNHC3100202	5/16



## TYPE 17 HEX HEAD WITHOUT SEAL (FULL THREAD)

*For general fastening to timber where a water tight seal is not necessary*



Product Description	Design Features	Pack Quantity	Pack Type	Product Code	Hexagonal Driver	Notes
<b>8g</b> - 15 x 20	CL4+, W	1000	Bulk	STHC4080202	<b>1/4</b>	
<b>10g</b> - 12 x 20	CL4+, W	1000	Bulk	STHC4100202	<b>5/16</b>	
<b>10g</b> - 12 x 25	Zn	1000	Bulk	STHCZ100252		
	Zn	100	Trade	STHCZ100258		
	CL4+, W	1000	Bulk	STHC4100252		
	CL4+, W	100	Trade	STHC4100258		
<b>10g</b> - 12 x 30	CL4+, W	1000	Bulk	STHC4100302		
	Zn	500	Bulk	STHCZ120252	<b>5/16</b>	
<b>12g</b> - 11 x 25	Zn	100	Trade	STHCZ120258		
	CL4+, W	500	Bulk	STHC4120252		
	CL4+, W	100	Trade	STHC4120258		
	B8(CAT5), W	500	Bulk	STHC8120252		
	B8(CAT5), W	100	Trade	STHC8120258		
	CL4+, W	500	Bulk	STHC4120302		
<b>12g</b> - 11 x 30	CL4+, W	100	Trade	STHC4120308		
	Zn	1000	Bulk	STHCZ120402		
<b>12g</b> - 11 x 40	CL4+, W	1000	Bulk	STHC4120402		
	CL4+, W	100	Trade	STHC4120408		
	Zn	1000	Bulk	STHCZ140252	<b>3/8</b>	
	Zn	100	Trade	STHCZ140258		
<b>14g</b> - 10 x 25	CL4+, W	2000	Bulk	STHC4140252		
	CL4+, W	100	Trade	STHC4140258		
	B8(CAT5), W	2000	Bulk	STHC8140252		
	B8(CAT5), W	100	Trade	STHC8140258		
<b>14g</b> - 10 x 40	CL4+, W	1000	Bulk	STHC4140402		





### TYPE 17 HEX WASHER HEAD WITHOUT SEAL (PART THREAD)

*For general fastening to timber where a water tight seal is not necessary*

Product Description	Design Features	Pack Quantity	Pack Type	Product Code	Hexagonal Notes Driver
<b>12g</b> - 11 x 45	Zn,SP	500	Bulk	STHCZ120452	<b>5/16</b>
	Zn,SP	100	Trade	STHCZ120458	
	CL4+, W,SP	1000	Bulk	STHC4120452	
	CL4+, W,SP	100	Trade	STHC4120458	
<b>12g</b> - 11 x 50	Zn,SP	1000	Bulk	STHCZ120502	
	Zn,SP	100	Trade	STHCZ120508	
	CL4+,W,SP	1000	Bulk	STHC4120502	
	CL4+,W,SP	100	Trade	STHC4120508	
<b>12g</b> - 11 x 65	Zn,SP	1000	Butk	STHCZ120652	
	Zn,SP	100	Trade	STHCZ120658	
	CL4+,W,SP	500	Bulk	STHC4120652	
<b>12g</b> - 11 x 75	CL4+, W,SP	500	Bulk	STHC4120752	
<b>14g</b> - 10 x 50	Zn,SP	1000	Bulk	STHCZ140502	<b>3/8</b>
	Zn,SP	100	Trade	STHCZ140508	
	CL4+, W,SP	1000	Bulk	STHC4140502	
	CL4+, W,SP	100	Trade	STHC4140508	
<b>14g</b> - 10 x 65	Zn,SP	500	Butk	STHCZ140652	
	Zn,SP	100	Trade	STHCZ140658	
	CL4+, W,SP	500	Bulk	STHC4140652	
	CL4+, W,SP	100	Trade	STHC4140658	
<b>14g</b> - 10 x 75	Zn,SP	500	Butk	STHCZ140752	
	Zn,SP	100	Trade	STHCZ140758	
	CL4+, W,SP	500	Bulk	STHC4140752	
	CL4+,W,SP	100	Trade	STHC4140758	
<b>14g</b> - 10 x 90	CL4+, W,SP	500	Butk	STHC4140902	
	CL4+, W,SP	100	Trade	STHC4140908	
<b>14g</b> - 10 x 100	CL4+, W,SP	250	Butk	STHC4141002	
	CL4+, W,SP	100	Trade	STHC4141008	
<b>14g</b> - 10 x 115	CL4+, W,SP	250	Butk	STHC4141152	
<b>14g</b> - 10 x 125	CL4+, W,SP	250	Bulk	STHC4141252	
<b>14g</b> - 10 x 150	CL4+, W,SP	250	Butk	STHC4141502	
<b>14g</b> - 10 x 175	CL4+, W,SP	200	Butk	STHC4141752	





## TYPE 17 HEX WASHER HEAD WITH SEAL (FULL THREAD)



*For general fastening to timber where a water tight seal is required*

Product Description	Design Features	Pack Quantity	Pack Type	Product Code	Hexagonal Driver	Notes
8g - 15 x 20	CL4+, W	1000	Bulk	STHC4080201	1/4	
10g - 12 x 20	CL4+,W	1000	Bulk	STHC4100201	5/16	
10g - 12 x 25	CL4+,W	1000	Bulk	STHC4100251		
	CL4+, W	100	Trade	STHC4100257		
10g - 12 x 30	CL4+, W	1000	Bulk	STHC4100301		
12g - 11 x 25	CL4+, W	500	Bulk	STHC4120251	5/16	
	CL4+, W	100	Trade	STHC4120257		
	B8(CAT5), W	500	Bulk	STHC8120251		
	B8(CAT5), W	100	Trade	STHC8120257		
12g - 11 x 35	CL4+, W	1000	Bulk	STHC4120351		
	Zn	1000	Bulk	STHCZ120401		
12g - 11 x 40	Zn	100	Trade	STHCZ120407		
	CL4+, W	1000	Bulk	STHC4120401		
	CL4+, W	100	Trade	STHC4120407		
	CL4+, W	2000	Bulk	STHC4120407		
14g - 10 x 25	CL4+, W	100	Trade	STHC4140251	3/8	
	B8(CAT5),W	2000	Bulk	STHC4140257		
	B8(CAT5),W	100	Trade	STHC8140251		
				STHC8140257		

### PRODUCT FEATURE KEY

- W Zn** Covered by the Bremick Warranty
- CL3+** Zinc Yellow
- CL4+** Corrosion protection to AS3566 Class 3 plus - Armourcoat®
- TG SP** Corrosion protection to AS3566 Class 4 plus - Armourcoat® 4
- SS B8** Top Grip®
- (CAT 5)** Shank Protector®
- Stainless Steel
- Revolution B8 Corrosion Protection to AS 3566 Class 4
- Suitable for use in ISO 9223 Category 5 Corrosive Environments (Very Severe Marine / Very Severe Industrial)



Tested and Certified in accordance with the design of buildings in cyclonic areas to Building Codes of Australia BCA 2006 Volume One Specification B 1.2. (Lo – Hi – Lo Cyclic Test Method.)



Northern Territory Building Approval Committee (NT BAC) approved for use in cyclonic areas and listed in the NT BAC Deemed To Comply Manual (NT DTCM).



Patent Protected



Stainless Steel Self Drilling Screw with carbon steel drill point capable of drilling into metal, over coated with an anti cease zinc rich coating.

Manufactured from Stainless Steel



Grade A4 -70 (Stainless Steel Grade 316)



Manufactured from Stainless Steel



Grade Patent Pending A2 -70 (Stainless Steel Grade 304)



### TYPE 17 HEX WASHER HEAD WITH SEAL (PART THREAD)

*For general fastening to timber where a water tight seal is required*

Product Description	Design Features	Pack Quantity	Pack Type	Product Code	Hexagonal Notes Driver
<b>12g</b> - 11 x 45	Zn,SP	500	Bulk	STHCZ120452	<b>5/16</b>
	CL4+, W,SP	1000	Bulk	STHC4120451	
	CL4+, W,SP	100	Trade	STHC4120457	
<b>12g</b> - 11 x 50	CL4+, W	1000	Bulk	STHC4120501	
	CL4+, W	100	Trade	STHC4120507	
<b>12g</b> - 11 x 65	CL4+, W,SP	500	Bulk	STHC4120651	
<b>12g</b> - 11 x 75	CL4+, W,SP	500	Bulk	STHC4120751	
<b>14g</b> - 10 x 50	CL4+, W,SP	1000	Bulk	STHC4140501	<b>3/8</b>
	CL4+, W,SP	100	Trade	STHC4140507	
<b>14g</b> - 10 x 65	CL4+, W,SP	500	Bulk	STHC4140651	
	CL4+, W,SP	100	Trade	STHC4140657	
<b>14g</b> - 10 x 75	CL4+, W,SP	500	Bulk	STHC4140751	
	CL4+, W,SP	100	Trade	STHC4140757	
<b>14g</b> - 10 x 90	CL4+, W,SP	500	Bulk	STHC4140901	
	CL4+, W,SP	100	Trade	STHC4140907	
<b>14g</b> - 10 x 100	CL4+, W,SP	250	Bulk	STHC4141001	
	CL4+, W,SP	100	Trade	STHC4141007	
	CL4+, W,SP	250	Bulk	STHC4141151	
<b>14g</b> - 10 x 115	CL4+, W,SP	250	Bulk	STHC4141251	
<b>14g</b> - 10 x 125	CL4+, W,SP	250	Bulk	STHC4141501	
<b>14g</b> - 10 x 150	CL4+, W,SP	200	Bulk	STHC4141751	
<b>14g</b> - 10 x 175					



## TYPE 17 TOPGRIP™ WITH SEAL

*For fastening the crest of roof sheeting to timber or thin steel where a water tight seal is required*



Product Description	Design Features	Pack Quantity	Pack Type	Product Code	Hexagonal Notes Driver
<b>12g</b> - 11 x 50	CL4+, W,TG, SP	1000	Bulk	STHT4120501	<b>5/16</b>
	CL4+, W,TG, SP	100	Trade	STHT4120507	
	B8(CAT5), W,TG, SP	1000	Bulk	STHT8120501	
	B8(CAT5), W,TG, SP	100	Trade	STHT8120507	
<b>12g</b> - 11 x 65	CL4+, W,TG,SP	500	Bulk	STHT4120651	
	CL4+, W,TG,SP	100	Trade	STHT4120657	
	B8(CAT5), W,TG, SP	500	Bulk	STHT8120651	
	B8(CAT5), W,TG, SP	100	Trade	STHT8120657	

## vortex<sup>TM</sup>roof UNIVERSAL ROOFING SCREW FOR TIMBER & METAL

*For fastening the crest of roof sheeting to timber battens, steel purlins or thin metal battens*



Product Description	Design Features	Pack Quantity	Pack Type	Product Code	Hexagonal Notes Driver
<b>M6.2</b> - 13 x 50	CL4+, TG, W	1000	Bulk	SUHT4620501	<b>5/16</b>
	CL4+, TG, W	100	Trade	SUHT4620507	
	B8(CAT5), TG, W	1000	Bulk	SUHT8620501	
	B8(CAT5), TG, W	100	Trade	SUHT8620507	
<b>M6.2</b> - 13 x 65	CL4+, TG, W	1000	Bulk	SUHT4620651	
	CL4+, TG, W	100	Trade	SUHT4620657	
	B8(CAT5), TG, W	1000	Bulk	SUHT8620651	
	B8(CAT5), TG, W	100	Trade	SUHT8620657	

## vortex<sup>TM</sup>battenfix UNIVERSAL SCREW

*For fastening thin metal battens and ceiling battens to timber or steel*



Product Description	Design Features	Pack Quantity	Pack Type	Product Code	Hexagonal Notes Driver
<b>12g</b> - 11 x 40	CL3+,W	1000	Bulk	SUHC3120402	<b>5/16</b>
	CL3+,W	100	Trade	SUHC3120408	
	CL4+,W	1000	Bulk	SUHC4120402	
	CL4+,W	100	Trade	SUHC4120408	



**TYPE 17 RIDGE ASSEMBLY  
HEX HEAD WASHER WITH 16mm  
ALUMINIUM 5251 / EPDM BONDED WASHER**

*For fastening the crests of roof sheeting to timber*

Product Description	Design Features	Pack Quantity	Pack Type	Product Code	Hexagonal Notes Driver
<b>14g - 10 x 50</b>	CL4+, W, SP	1000	Bulk	STHC4140504	<b>3/8</b>
<b>14g - 10 x 65</b>	CL4+, W, SP	500	Bulk	STHC4140654	



**TYPE 17 RIDGE ASSEMBLY  
HEX HEAD WASHER WITH 19mm  
ALUMINIUM 5251 / EPDM BONDED WASHER**

*For fastening metal ridges and flashings to timber*

Product Description	Design Features	Pack Quantity	Pack Type	Product Code	Hexagonal Notes Driver
<b>14g - 10 x 50</b>	CL4+, W, SP	500	Bulk	STHC4140505	<b>3/8</b>
<b>14g - 10 x 65</b>	CL4+, W, SP	500	Bulk	STHC4140655	



**TYPE 17 RIDGE ASSEMBLY  
HEX HEAD WASHER WITH 25mm  
ALUMINIUM 5251 / EPDM BONDED WASHER**

*For fastening metal ridges and flashings to timber*

Product Description	Design Features	Pack Quantity	Pack Type	Product Code	Hexagonal Notes Driver
<b>14g - 10 x 50</b>	CL4+, W, SP	250	Bulk	STHC4140506	<b>3/8</b>
<b>14g - 10 x 65</b>	CL4+, W, SP	250	Bulk	STHC4140656	
<b>14g - 10 x 75</b>	CL4+, W, SP	250	Bulk	STHC4140756	



## vortexcyclone UNIVERSAL CYCLONE ASSEMBLIES FOR STEEL & TIMBER

*For fastening the crest of corrugated and square rib profiles to timber, thin metal battens and steel purlins*



Product Description	Design Features	Pack Quantity	Pack Type	Product Code	Hexagonal Notes Driver
<b>M6.2</b> - 13 x 55	CL4+, TG, W	250	Bulk	SUHC462055D	<b>3/8</b>
	B8(CAT5), TG, W	250	Bulk	SUHC862055D	
<b>M6.2</b> - 13 x 65	CL4+, TG, W	250	Bulk	SUHC462065D	
	B8(CAT5), TG, W	250	Bulk	SUHC862065D	
<b>M6.2</b> - 13 x 95	CL4+, TG, W	250	Bulk	SUHC462095D	

## CYCLONE ASSEMBLIES - BRA TYPE 17 ROOFING ASSEMBLY - PART THREAD

*For fastening the crest of corrugated and square rib profiles to timber and thin metal battens.*



Product Description	Design Features	Pack Quantity	Pack Type	Product Code	Hexagonal Notes Driver
<b>14g</b> - 10 x 75	CL4+, W, SP	250	Bulk	STHC414075B	<b>3/8</b>
<b>14g</b> - 10 x 90	CL4+, W, SP	250	Bulk	STHC414090B	
<b>14g</b> - 10 x 100	CL4+, W, SP	250	Bulk	STHC414100B	
<b>14g</b> - 10 x 115	CL4+, W, SP	250	Bulk	STHC414115B	
<b>14g</b> - 10 x 125	CL4+, W, SP	250	Bulk	STHC414125B	
<b>14g</b> - 10 x 150	CL4+, W, SP	250	Bulk	STHC414150B	
<b>14g</b> - 10 x 175	CL4+, W, SP	250	Bulk	STHC414175B	



### CYCLONE ASSEMBLIES - BRA

#### TYPE 17 ROOFING ASSEMBLY - FULL THREAD

*For fastening the crest of corrugated and square rib profiles to timber and thin metal battens.*

Product Description	Design Features	Pack Quantity	Pack Type	Product Code	Hexagonal Notes Driver
14g - 10 x 50	CL4+, SP	250	Bulk	STHC414050D	3/8
14g - 10 x 65	CL4+, SP	250	Bulk	STHC414065D	
14g - 10 x 75	CL4+, SP	250	Bulk	STHC414075D	



### STAINLESS STEEL 300 SERIES (A2)

#### CYCLONE ASSEMBLIES - BRA

#### TYPE ROOFING ASSEMBLY - FULL THREAD

*For fastening the crest of Aluminium corrugated and square rib profiles to timber*

Product Description	Design Features	Pack Quantity	Pack Type	Product Code	Hexagonal Notes Driver
14g - 10 x 50	SS	250	Bulk	STHC514050D	3/8
14g - 10 x 65	SS	250	Bulk	STHC514065D	



### CYCLONE ASSEMBLIES -

#### TYPE 17 CUSTOM® ORB

*For fastening the crest of corrugated profiles to timber and thin metal battens*

Product Description	Design Features	Pack Quantity	Pack Type	Product Code	Hexagonal Notes Driver
14g - 10 x 50	CL4+, W, SP	200	Bulk	STHC414050C	3/8
14g - 10 x 65	CL4+, W, SP	200	Bulk	STHC414065C	
14g - 10 x 75	CL4+, W, SP	200	Bulk	STHC414075C	



**CYCLONE ASSEMBLIES -  
TYPE 17 TRIMDEK® / SPANDEK®**

*For fastening the crest of square rib profiles to timber and thin metal battens*



Product Description	Design Features	Pack Quantity	Pack Type	Product Code	Hexagonal Notes Driver
14g - 10 x 65	CL4+, W, SP	200	Bulk	STHC414065T	3/8
14g - 10 x 75	CL4+, W, SP	200	Bulk	STHC414075T	

**CYCLONE ASSEMBLIES -  
TYPE 17 KLIPOK®**

*For fastening the crest of secret clip profiles to timber and thin metal battens*



Product Description	Design Features	Pack Quantity	Pack Type	Product Code	Hexagonal Notes Driver
14g - 10 x 75	CL4+, W, SP	200	Bulk	STHC414075K	3/8

**CYCLONE ASSEMBLIES -  
TYPE 17 KINGKLIP®**

*For fastening the crest of secret clip profiles to timber and thin metal battens*



Product Description	Design Features	Pack Quantity	Pack Type	Product Code	Hexagonal Notes Driver
14g - 10 x 65	CL4+, W	200	Bulk	STHC414065F	3/8
14g - 10 x 75	CL4+, W	200	Bulk	STHC414075F	

**ROOFING ASSEMBLIES -  
TYPE 17 POLYCARBONATE**

*For fastening the crest of polycarbonate profiles to timber*



Product Description	Design Features	Pack Quantity	Pack Type	Product Code	Hexagonal Notes Driver
12g - 11 x 50	CL4+, W, SP	500	Bulk	STHC412050P	5/16

CUSTOM ORB®, TRIMDEK®, SPANDEK® and KLIPOK® are registered trade marks of BlueScope Steel Limited.  
KINGKLIP is a registered trademark of Fielders Limited.



PATENT  
PENDING

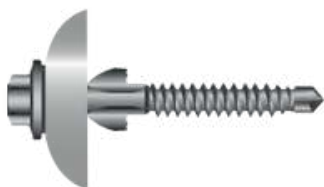

**vortex**<sup>TM</sup>poly

UNIVERSAL POLYCARBONATE ASSEMBLY  
FOR TIMBER OR STEEL

*For fastening the crests of Polycarbonate roof sheeting  
to timber battens or steel.  
With cutting fl ns for automatic forming of expansion hole.*

Product Description	Design Features	Pack Quantity	Pack Type	Product Code	Hexagonal Notes Driver
<b>M6.2</b> -13 x 50	CL4+, W	250	Bulk	SUHT462050P	<b>5/16</b>
		100	Trade	TUHT462050P	
<b>M6.2</b> -13 x 65	CL4+, W	250	Bulk	SUHT462065P	<b>5/16</b>
		100	Trade	TUHT462065P	

PATENT  
PENDING



**vortex**<sup>TM</sup>fibreglass

METAL DRILLING FIBREGLASS  
ASSEMBLY FOR STEEL

*For fastening the crests of Fibreglass roof  
sheeting to steel purlins. With cutting fl ns for  
automatic forming of expansion hole.*

Product Description	Design Features	Pack Quantity	Pack Type	Product Code	Hexagonal Notes Driver
<b>12g</b> - 13 x 65	CL4+, W	250	Bulk	SMHC412065G	<b>5/16</b>
		100	Trade	TMHC412065G	

**vortex**<sup>TM</sup>mini

RAISED PHILLIPS HEAD CL3

*For fastening the valley of mini-corrugated  
sheeting to steel or timber*



Product Description	Design Features	Pack Quantity	Pack Type	Product Code	Phillips Driver	Notes
<b>10g</b> - 14 x 20	CL3+, W	1000	Bulk	SUMC3100202	<b>No. 2</b>	
		100	Trade			
<b>10g</b> - 14 x 30	CL3+, W	1000	Bulk	SUMC3100302		
		100	Trade			



**vortexclad**

*For fastening the valley of steel walling  
profiles to steel or timber - Without Seal*



Product Description	Design Features	Pack Quantity	Pack Type	Product Code	Hexagonal Notes Driver
<b>M5.4 - 14 x 25</b>	CL4, W	500	Bulk	SUHC4540252	<b>5/16</b>
B8(CAT5), W 500 Bulk SUHC8540252					

**vortexclad**

*For fastening the valley of steel walling  
profiles to steel or timber - With Seal*



Product Description	Design Features	Pack Quantity	Pack Type	Product Code	Hexagonal Notes Driver
<b>M5.4 - 14 x 25</b>	CL4, W	500	Bulk	SUHC4540251	<b>5/16</b>
B8(CAT5), W 500 Bulk SUHC8540251					

**vortexclad**

*For fastening the valley of steel walling  
profiles to steel or timber in high  
wind areas - Without Seal*



Product Description	Design Features	Pack Quantity	Pack Type	Product Code	Hexagonal Notes Driver
<b>M6.2 - 13 x 25</b>	CL4, W	500	Bulk	SUHC4620252	<b>5/16</b>
B8(CAT5), W 500 Bulk SUHC8620252					

**vortexclad**

*For fastening the valley of steel walling  
profiles to steel or timber in high  
wind areas - With Seal*



Product Description	Design Features	Pack Quantity	Pack Type	Product Code	Hexagonal Notes Driver
<b>M6.2 - 13 x 25</b>	CL4, W	500	Bulk	SUHC4620251	<b>5/16</b>
B8(CAT5), W 500 Bulk SUHC8620251					



## TYPE 17 WAFER HEAD

*For fastening into timber where a flat head is required*

Product Description	Design Features	Pack Quantity	Pack Type	Product Code	Phillips Driver	Notes
<b>10g - 12 x 25</b>	Zn	1000	Bulk	STWCZ100252	<b>No. 2</b>	
	Zn	100	Trade	STWCZ100258		
	CL3+, W	1000	Bulk	STWC3100252		
	CL3+, W	100	Trade	STWC3100258		
<b>10g - 12 x 35</b>	Zn	1000	Bulk	STWCZ100352		
	Zn	100	Trade	STWCZ100358		
	CL3+, W	1000	Bulk	STWC3100352		
	CL3+, W	100	Trade	STWC3100358		
<b>10g - 12 x 45</b>	Zn	2000	Bulk	STWCZ100452		
	Zn	100	Trade	STWCZ100458		
	CL3+, W	2000	Bulk	STWC3100452		
	CL3+, W	100	Trade	STWC3100458		
<b>10g - 12 x 50</b>	Zn	2000	Bulk	STWCZ100502		

## PRODUCT FEATURE KEY

<b>W Zn</b>	Covered by the Bremick Warranty
<b>CL3+</b>	Zinc Yellow
<b>CL4+</b>	Corrosion protection to AS3566 Class 3 plus - Armourcoat®
<b>TG SP</b>	Corrosion protection to AS3566 Class 4 plus - Armourcoat® 4
<b>SS B8</b>	Top Grip®
<b>(CAT 5)</b>	Shank Protector®
	Stainless Steel
	Revolution B8 Corrosion Protection to AS 3566 Class 4
	Suitable for use in ISO 9223 Category 5 Corrosive Environments (Very Severe Marine / Very Severe Industrial)



Tested and Certified in accordance with the design of buildings in cyclonic areas to Building Codes of Australia BCA 2006 Volume One Specification B 1.2. (Lo – Hi – Lo Cyclic Test Method.)



Northern Territory Building Approval Committee (NT BAC) approved for use in cyclonic areas and listed in the NT BAC Deemed To Comply Manual (NT DTCM).



Patent Protected



Stainless Steel Self Drilling Screw with carbon steel drill point capable of drilling into metal, over coated with an anti cease zinc rich coating.



Manufactured from Stainless Steel



Grade

A4 -70 (Stainless Steel Grade 316)

Manufactured from Stainless Steel



Grade

Patent Pending

A2 -70 (Stainless Steel Grade 304)



## TYPE 17 BUGLE HEAD BATTEN

*For flush fastening of heavy duty timbers*



Product Description	Design Features	Pack Quantity	Pack Type	Product Code	Hex Driver Bit	Notes
<b>14g - 10 x 50</b>	Zn	1000	Bulk	SBBCZ140502	<b>5mm</b>	
	Zn	1000	Bulk Plastic	SBPCZ140502		
	Zn	100	Trade	SBBCZ140508		
	CL3+, W	1000	Bulk	SBBC3140502		
	CL3+, W	1000	Bulk Plastic	SBPC3140502		
	CL3+, W	100	Trade	SBBC3140508		
<b>14g - 10 x 75</b>	Zn	500	Bulk	SBBCZ140752		
	Zn	500	Bulk Plastic	SBPCZ140752		
	Zn	100	Trade	SBBCZ140758		
	CL3+, W	500	Bulk	SBBC3140752		
	CL3+, W	500	Bulk Plastic	SBPC3140752		
	CL3+, W	100	Trade	SBBC3140758		
<b>14g - 10 x 85</b>	CL3+, W	1000	Bulk	SBBC3140852		
	CL3+, W	100	Trade	SBBC3140858		
	Zn	500	Bulk	SBBCZ141002		
<b>14g - 10 x 100</b>	Zn	500	Bulk Plastic	SBPCZ141002		
	Zn	100	Trade	SBBCZ141008		
	CL3+, W	500	Bulk	SBBC3141002		
	CL3+, W	500	Bulk Plastic	SBPC3141002		
	CL3+, W	100	Trade	SBBC3141008		
	CL3+, W	250	Bulk	SBBC3141252		
<b>14g - 10 x 125</b>	CL3+, W	250	Bulk Plastic	SBPC3141252		
	CL3+, W	100	Trade	SBBC3141258		
	CL3+, W	250	Bulk	SBBC3141502		
<b>14g - 10 x 150</b>	CL3+, W	250	Bulk Plastic	SBPC3141502		

## FACIA / GUTTER SCREW - NEEDLE POINT WAFER HEAD - Square Drive

*For fastening of gutter brackets to timber fascia or fastening to timber where a flat head is required*



Product Description	Design Features	Pack Quantity	Pack Type	Product Code	Square Driver	Notes
<b>8g - 10 x 25</b>	CL4+, W	1000	Bulk	STWC4080252	<b>No. 2</b>	
	CL4+, W	100	Trade	STWC4080258		



### TYPE 17 SELF EMBEDDING - FLOWER HEAD

*For fastening rigid boards to timber*

Product Description	Design Features	Pack Quantity	Pack Type	Product Code	Phillips Driver	Notes
8g - 18 x 30	Zn	1000	Bulk	STECZ080302	No. 2	
8g - 18 x 40	Zn	1000	Bulk	STECZ080402		
10g - 12 x 45	Zn	500	Bulk	STECZ100452	No. 2	
	CL3+, W	500	Bulk	STEC3100452		



### TYPE 17 COUNTERSUNK HEAD

ZINC YELLOW

*For fastening pre-drilled fixtures to timber or thin steel*

Product Description	Design Features	Pack Quantity	Pack Type	Product Code	Phillips Driver	Notes
6g - 18 x 25	Zn	1000	Bulk	STKCZ060252	No. 2	
	Zn	100	Trade	STKCZ060258		
8g - 15 x 20	Zn	1000	Bulk	STKCZ080202	No. 2	
	Zn	100	Trade	STKCZ080208		
8g - 15 x 25	Zn	1000	Bulk	STKCZ080252	No. 2	
	Zn	100	Trade	STKCZ080258		
10g - 12 x 30	Zn	1000	Bulk	STKCZ100302	No. 2	
	Zn	100	Trade	STKCZ100308		
10g - 12 x 40	Zn	1000	Bulk	STKCZ100402	No. 2	
	Zn	100	Trade	STKCZ100408		
10g - 12 x 50	Zn	500	Bulk	STKCZ100502	No. 2	
	Zn	100	Trade	STKCZ100508		
10g - 12 x 75	Zn	1000	Bulk	STKCZ100752	No. 2	
	Zn	100	Trade	STKCZ100758		



### TYPE 17 COUNTERSUNK RIB HEAD

*For fastening sheeting / fibre cement where a self embedding head is required*

Product Description	Design Features	Pack Quantity	Pack Type	Product Code	Phillips Driver	Notes
8g - 18 x 30	Zn	1000	Bulk	STRCZ080302	No. 2	
8g - 18 x 40	Zn	1000	Bulk	STRCZ080402		
10g - 12 x 40	Zn	500	Bulk	STRCZ100402	No. 2	
10g - 12 x 45	Zn	500	Bulk	STRCZ100452		





## TYPE 17 PAN HEAD



*For general fastening to timber where a raised head is required*

Product Description	Design Features	Pack Quantity	Pack Type	Product Code	Phillips Driver	Notes
8g - 15 x 20	Zn	1000	Bulk	STPCZ080202	No. 2	
	Zn	100	Trade	STPCZ080208		
8g - 15 x 25	Zn	1000	Bulk	STPCZ080252		
	Zn	100	Trade	STPCZ080258		

## vortex<sup>TM</sup> fibre

### COUNTERSUNK RIBBED HEAD (FOR 6-12mm SHEETING)

*For fastening non-compressed fibre cement boards to timber & steel up to 1.6mm thick*



Product Description	Design Features	Pack Quantity	Pack Type	Product Code	Square Driver	Notes
M5 - 14 x 20	CL3+, W	1000	Bulk	SURC3500202	No. 2	
	Zn	1000	Bulk	SURCZ500202		
M5 - 14 x 30	CL3+, W	1000	Bulk	SURC3500302		
	Zn	1000	Bulk	SURCZ500302		

## vortex<sup>TM</sup> fibre

### BUGLE HEAD (FOR 4.5mm SHEETING)

*For fastening non-compressed fibre cement boards to timber & steel up to 1.6mm thick*



Product Description	Design Features	Pack Quantity	Pack Type	Product Code	Phillips Driver	Notes
M5 - 14 x 20	CL3+, W	1000	Bulk	SUUC3500202	No. 2	
	Zn	1000	Bulk	SUUCZ500202		

**300 SERIES (A2) - TYPE 17  
HEXAGONAL HEAD - WITHOUT SEAL**

*For general fastening of timber or aluminium in corrosive areas*

Product Description	Design Features	Pack Quantity	Pack Type	Product Code	Hexagonal Notes Driver
<b>12g</b> - 11 x 25	SS	1000	Bulk	STHC5120252	<b>5/16</b>
<b>12g</b> - 11 x 50	SS	1000	Bulk	STHC5120502	
<b>12g</b> - 11 x 65	SS	500	Bulk	STHC5120652	
<b>14g</b> - 10 x 25	SS	500	Bulk	STHC5140252	<b>3/8</b>
<b>14g</b> - 10 x 35	SS	500	Bulk	STHC5140352	
<b>14g</b> - 10 x 35	SS	100	Trade	STHC5140358	
<b>14g</b> - 10 x 50	SS	1000	Bulk	STHC5140502	
<b>14g</b> - 10 x 50	SS	1000	Bulk	STHC5140652	
<b>14g</b> - 10 x 65	SS	500	Bulk	STHC5140752	
<b>14g</b> - 10 x 75	SS	500	Bulk	STHC5140902	
<b>14g</b> - 10 x 90	SS	500	Bulk	STHC5141152	
<b>14g</b> - 10 x 115	SS	500	Bulk	STHC5141252	
<b>14g</b> - 10 x 125	SS	500	Bulk	STHC5141502	
<b>14g</b> - 10 x 150	SS	500	Bulk	STHC5141752	
<b>14g</b> - 10 x 175					

**300 SERIES (A2) - TYPE 17  
HEXAGONAL HEAD - WITH SEAL**

*For general fastening of timber or aluminium in corrosive areas*

Product Description	Design Features	Pack Quantity	Pack Type	Product Code	Hexagonal Notes Driver
<b>12g</b> - 11 x 25	SS	1000	Bulk	STHC5120251	<b>5/16</b>
<b>12g</b> - 11 x 50	SS	1000	Bulk	STHC5120501	
<b>12g</b> - 11 x 65	SS	500	Bulk	STHC5120651	
<b>14g</b> - 10 x 25	SS	500	Bulk	STHC5140251	<b>3/8</b>
<b>14g</b> - 10 x 35	SS	500	Bulk	STHC5140351	
<b>14g</b> - 10 x 35	SS	100	Trade	STHC5140357	
<b>14g</b> - 10 x 50	SS	1000	Bulk	STHC5140501	
<b>14g</b> - 10 x 50	SS	1000	Bulk	STHC5140651	
<b>14g</b> - 10 x 65	SS	500	Bulk	STHC5140751	
<b>14g</b> - 10 x 75	SS	500	Bulk	STHC5140901	
<b>14g</b> - 10 x 90	SS	1000	Bulk	STHC5141151	
<b>14g</b> - 10 x 115	SS	1000	Bulk	STHC5141251	
<b>14g</b> - 10 x 125	SS	500	Bulk	STHC5141501	
<b>14g</b> - 10 x 150	SS	500	Bulk	STHC5141751	
<b>14g</b> - 10 x 175					



## 300 SERIES (A2) - TYPE 17 HEXAGONAL HEAD CYCLONE ASSEMBLIES - BRA

**BREMICK ROOFING ASSEMBLY - FULL THREAD**

*For fastening the crest of Aluminium corrugated and square rib profiles to timber*



Product Description	Design Features	Pack Quantity	Pack Type	Product Code	Hexagonal Driver	Notes
14g - 10 x 50	SS	250	Bulk	STHC514050D	3/8	
14g - 10 x 65	SS	250	Bulk	STHC514065D		

## 300 SERIES (A2) - TYPE 17

**HEXAGONAL HEAD - WITH 16mm ALUMINIUM BONDED WASHER**

*For general fastening of timber or aluminium in corrosive areas*



Product Description	Design Features	Pack Quantity	Pack Type	Product Code	Hexagonal Driver	Notes
14g - 10 x 25	SS	500	Bulk	STHC5140254	3/8	
14g - 10 x 35	SS	500	Bulk	STHC5140354		
14g - 10 x 50	SS	1000	Bulk	STHC5140504		
14g - 10 x 65	SS	1000	Bulk	STHC5140654		
14g - 10 x 75	SS	500	Bulk	STHC5140754		
14g - 10 x 90	SS	500	Bulk	STHC5140904		
14g - 10 x 115	SS	250	Bulk	STHC5141154		
14g - 10 x 125	SS	250	Bulk	STHC5141254		
14g - 10 x 150	SS	200	Bulk	STHC5141504		
14g - 10 x 175	SS	200	Bulk	STHC5141754		

## 316 SERIES (A4) - TYPE 17

**HEXAGONAL HEAD WASHER HEAD WITHOUT SEAL**

*For general fastening of timber or aluminium in corrosive areas*



Product Description	Design Features	Pack Quantity	Pack Type	Product Code	Hexagonal Driver	Notes
14g - 10 x 50	SS	500	Bulk	STHC6140502	3/8	
14g - 10 x 65	SS	500	Bulk	STHC6140652		
14g - 10 x 75	SS	500	Bulk	STHC6140752		
14g - 10 x 85	SS	500	Bulk	STHC6140852		
14g - 10 x 90	SS	100	Bulk	STHC6140902		
14g - 10 x 115	SS	250	Bulk	STHC6141152		
14g - 10 x 125	SS	250	Bulk	STHC6141252		
14g - 10 x 150	SS	200	Bulk	STHC6141502		
14g - 10 x 175	SS	200	Bulk	STHC6141752		



### 300 SERIES (A2) - TYPE 17 RIBBED BUGLE BATTEN FOR TIMBER

*For flush fastening of heavy duty timber & aluminium in corrosive areas*

Product Description	Design Features	Pack Quantity	Pack Type	Product Code	Hex Driver Bit	Notes
14g - 10 x 50	SS	1000	Bulk	SBBC5140502	5mm	
14g - 10 x 75	SS	500	Bulk	SBBC5140752		
14g - 10 x 100	SS	500	Bulk	SBBC5141002		
14g - 10 x 150	SS	000	Bulk	SBBC5141502		



### 316 SERIES (A4) - TYPE 17 - RIBBED BUGLE BATTEN FOR TIMBER

*For flush fastening of heavy duty timber in highly corrosive areas*

Product Description	Design Features	Pack Quantity	Pack Type	Product Code	Hex Driver Bit	Notes
14g - 10 x 50 -	SS	1000	Bulk	SBBC6140502	5mm	
14g 10 x 75 -	SS	500	Bulk	SBBC6140752		
14g 10 x 100	SS	500	Bulk	SBBC6141002		



### 304 SERIES (A2) - DECKING SCREW COUNTERSUNK RIBBED HEAD, SQUARE DRIVE

*For fastening timber decking in corrosive areas*

Product Description	Design Features	Pack Quantity	Pack Type	Product Code	Square Driver Bit	Notes
8g - 10x 50	SS	500	Bulk	STQC5080502	No. 2	
	SS	100	Trade	STQC5080508		
8g - 10 x 65	SS	500	Bulk	STQC5080652		
	SS	100	Trade	STQC5080658		
10g - 12 x 50	SS	500	Bulk	STQC5100502		
	SS	100	Trade	STQC5100508		
10g - 12 x 65	SS	500	Bulk	STQC5100652		
	SS	100	Trade	STQC5100658		



### 316 SERIES (A4) - DECKING SCREW COUNTERSUNK RIBBED HEAD, SQUARE DRIVE

*For fastening timber decking in highly corrosive areas*

Product Description	Design Features	Pack Quantity	Pack Type	Product Code	Square Driver Bit	Notes
10g - 12 x 50	SS	500	Bulk	STQC6100502	No. 2	
10g - 12 x 65	SS	500	Bulk	STQC6100652		



## vortex<sup>TM</sup> deck

### 316 SERIES (A4) - DECKING SCREW

SELF EMBEDDING BULLET HEAD, SQUARE DRIVE *For one step fastening of timber decking boards to timber in highly corrosive areas.*



Product Description	Design Features	Pack Quantity	Pack Type	Product Code	Square Driver Bit	Notes
<b>10g</b> - 11 x 50	SS 316	500	Bulk	SMQC6500502	<b>No. 2</b>	
	SS 316	100	Trade	SMQC6500508		
<b>10g</b> - 11 x 65	SS 316	500	Bulk	SMQC6500652		
	SS 316	100	Trade	SMQC6500658		

### 300 SERIES (A2) - STITCHING SCREWS

HEXAGON SLOTTED NEEDLE POINT WITH SERRATION UNDER HEAD

*For fastening of timber and thin steel in corrosive areas*



Product Description	Design Features	Pack Quantity	Pack Type	Product Code	Hexagonal Driver	Notes
<b>8g</b> - 15 x 15	SS	1000	Bulk	SNXC5080152	<b>1/4</b>	

### 304 SERIES (A2)

BI METAL SELF DRILLING SCREW - WITH ANTI CEASE COATING  
HEXAGONAL WASHER HEAD - WITHOUT SEAL

*For fastening to steel or aluminium in corrosive areas  
Self drilling into Steel up to 6.5 mm thick*



Product Description	Design Features	Pack Quantity	Pack Type	Product Code	Hexagonal Driver	Notes
<b>10g</b> - 16 x 19	SS	500	Bulk	SMHC6100192	<b>5/16</b>	
<b>12g</b> - 14 x 20	SS	500	Bulk	SMHC6120202	<b>5/16</b>	
<b>14g</b> - 14 x 25	SS	1000	Bulk	SMHC6140252	<b>3/8</b>	
<b>14g</b> - 14 x 31	SS	500	Bulk	SMHC6140312		
<b>14g</b> - 14 x 50	SS	1000	Bulk	SMHC6140502		
<b>14g</b> - 14 x 70	SS	500	Bulk	SMHC6140702		
<b>14g</b> - 14 x 80	SS	250	Bulk	SMHC6140802		
<b>14g</b> - 14 x 95	SS	250	Bulk	SMHC6140952		
<b>14g</b> - 14 x 115	SS	250	Bulk	SMHC6141152		
<b>14g</b> - 14 x 135	SS	250	Bulk	SMHC6141352		
<b>14g</b> - 14 x 150	SS	250	Bulk	SMHC6141502		
<b>14g</b> - 14 x 175				SMHC6141752		



**WITH ANTI CEASE COATING  
HEXAGONAL WASHER HEAD - WITH SEAL**

*For fastening to metal in corrosive areas. Self drilling into Steel up to 6.5 mm thick*

**304 SERIES (A2)  
BI METAL SELF DRILLING SCREW -**

Product Type	Description	Design Features	Pack Quantity	Product Code	Hexagonal Driver	Notes
10g	16 x 19	SS	500	SMHC6100191	5/16	
12g	14 x 20	SS	1000	SMHC6120201		
14g	14 x 25	SS	1000	SMHC6140251	3/8	
Bulk	14 x 31	SS	500	SMHC6140311		
Bulk	14 x 31	SS	1000	SMHC6140501		
Bulk	14 x 50	SS	500	SMHC6140701		
Bulk	14 x 70	SS	500	SMHC6140801		
Bulk	14 x 80	SS	250	SMHC6140951		
Bulk	14 x 95	SS	250	SMHC6141151		
Bulk	14 x 115	SS	250	SMHC6141351		
Bulk	14 x 135	SS	200	SMHC6141501		
Bulk	14 x 150	SS	200	SMHC6141751		
14g	14 x 175					



**304 SERIES (A2)  
STAINLESS STEEL CYCLONE ASSEMBLIES  
BRA (ALUMINIUM/EPDM)  
BI METAL SELF DRILLING SCREW - WITH ANTI CEASE COATING  
BREMICK ROOFING ASSEMBLY - FULL THREAD**  
*For fastening the crest of corrugated and square rib  
Aluminium profiles to metal purlins upto 6.5mm thick*

Product Description	Design Features	Pack Quantity	Pack Type	Product Code	Hexagonal Driver	Notes
14g - 14 x 50	SS	250	Bulk	SMHC614050D	3/8	
14g - 14 x 65	SS	250	Bulk	SMHC614065D		



**304 SERIES (A2)  
BI METAL SELF DRILLING SCREW - WITH ANTI CEASE  
COATING HEX HEAD - WITH 16mm ALUMINIUM BONDED WASHER**  
*For fastening to metal in corrosive areas. Self drilling into Steel up to 6.5 mm thick*

Product Description	Design Features	Pack Quantity	Pack Type	Product Code	Hexagonal Driver	Notes
14g - 14 x 25	SS	1000	Bulk	SMHC6140254	3/8	
14g - 14 x 31	SS	500	Bulk	SMHC6140314		
14g - 14 x 50	SS	1000	Bulk	SMHC6140504		
14g - 14 x 70	SS	500	Bulk	SMHC6140704		
14g - 14 x 80	SS	500	Bulk	SMHC6140804		
14g - 14 x 80	SS	250	Bulk	SMHC6140954		
14g - 14 x 95	SS	250	Bulk	SMHC6141154		
14g - 14 x 115	SS	250	Bulk	SMHC6141354		
14g - 14 x 135	SS	200	Bulk	SMHC6141504		
14g - 14 x 150	SS	200	Bulk	SMHC6141754		
14g - 14 x 175						



**304 SERIES (A2)****WING DRILLER - COUNTERSUNK RIB HEAD***For flush fastening timber materials to metal in corrosive areas*

Product Description	Design Features	Pack Quantity	Pack Type	Product Code	Phillips Driver	Notes
<b>10g</b> - 16 x 45	SS	500	Bulk	SWRC6100452	<b>No. 2</b>	

**304 SERIES (A2)****WAFER HEAD***For fastening to steel in corrosive areas*

Product Description	Design Features	Pack Quantity	Pack Type	Product Code	Phillips Driver	Notes
<b>10g</b> - 16 x 25	SS	500	Bulk	SMWC5100252	<b>No. 2</b>	

**304 SERIES (A2)****DEEP DRILLER - HEX WASHER HEAD WITHOUT SEAL***For fastening into thick metals up to 12.5mm thick in corrosive areas where a water tight seal is not necessary.*

Product Description	Design Features	Pack Quantity	Pack Type	Product Code	Hexagonal Driver	Notes
<b>12g</b> - 24 x 32	SS	500	Bulk	S5HC6120322	<b>5/16</b>	
<b>12g</b> - 24 x 50	SS	500	Bulk	S5HC6120502		
<b>12g</b> - 24 x 65	SS	500	Bulk	S5HC6120652		
<b>14g</b> - 24 x 65	SS	250	Bulk	S5HC6140652	<b>3/8</b>	
<b>14g</b> - 24 x 95	SS	250	Bulk	S5HC6140952		
<b>14g</b> - 24 x 115	SS	250	Bulk	S5HC6141152		
<b>14g</b> - 24 x 150	SS	250	Bulk	S5HC6141502		
<b>14g</b> - 24 x 175				S5HC6141752		

**304 SERIES (A2)****DEEP DRILLER - HEX WASHER HEAD WITH SEAL***For fastening into thick metals up to 12.5mm thick in corrosive areas where a water tight seal is required*

Product Description	Design Features	Pack Quantity	Pac	Product Code	Hexagonal Driver	Notes
<b>12g</b> - 24 x 32	SS	500		S5HC6120321	<b>5/16</b>	
<b>12g</b> - 24 x 50	SS	500	Typ	S5HC6120501		
<b>12g</b> - 24 x 65	SS	500	Bulk	S5HC6120651		
<b>14g</b> - 24 x 65	SS	500	Bulk	S5HC6140651	<b>3/8</b>	
<b>14g</b> - 24 x 95	SS	500	Bulk	S5HC6140951		
<b>14g</b> - 24 x	SS	500	Bulk	S5HC6141151		
<b>115 14g</b> - 24	SS	500	Bulk	S5HC6141501		
<b>x 150 14g</b> -			Bulk	S5HC6141751		
<b>24 x 175</b>			Bulk			



**COUNTERSUNK RIB HEAD  
ZINC YELLOW - PHILLIPS DRIVE**

*For fastening chipboard, composite board or  
timber to timber*

Product Description	Design Features	Pack Quantity	Pack Type	Product Code	Phillips Driver	Notes
<b>8g</b> - 10 x 20	Zn	1000	Bulk	SCHCZ080202	<b>No 2</b>	
	Zn	100	Trade	SCHCZ080208		
<b>8g</b> - 10 x 25	Zn	1000	Bulk	SCHCZ080252		
	Zn	100	Trade	SCHCZ080258		
<b>8g</b> - 10 x 28	Zn	1000	Bulk	SCHCZ080282		
	Zn	100	Trade	SCHCZ080288		
<b>8g</b> - 10 x 32	Zn	1000	Bulk	SCHCZ080322		
	Zn	100	Trade	SCHCZ080328		
<b>8g</b> - 10 x 35	Zn	1000	Bulk	SCHCZ080352		
	Zn	100	Trade	SCHCZ080358		
<b>8g</b> - 10 x 40	Zn	1000	Bulk	SCHCZ080402		
	Zn	100	Trade	SCHCZ080408		
<b>8g</b> - 10 x 45	Zn	1000	Bulk	SCHCZ080452		
	Zn	100	Trade	SCHCZ080458		
<b>8g</b> - 10 x 50	Zn	1000	Bulk	SCHCZ080502		
	Zn	100	Trade	SCHCZ080508		
<b>8g</b> - 10 x 57	Zn	1000	Bulk	SCHCZ080572		
	Zn	100	Trade	SCHCZ080578		
<b>8g</b> - 10 x 65	Zn	100	Trade	SCHCZ080652		
	Zn	500	Bulk	SCHCZ080658		
<b>10g</b> - 8 x 65	Zn	1000	Bulk	SCHCZ100652	<b>No 2</b>	
	Zn	100	Trade	SCHCZ100658		
<b>10g</b> - 8 x 75	Zn	1000	Bulk	SCHCZ100752		
	Zn	100	Trade	SCHCZ100758		
<b>10g</b> - 8 x 100	Zn	1000	Bulk	SCHCZ101002		
	Zn	100	Trade	SCHCZ101008		

## PRODUCT FEATURE KEY

<b>W</b>	<b>Zn</b>	Covered by the Bremick Warranty
<b>CL3+</b>		Zinc Yellow
<b>CL4+</b>		Corrosion protection to AS3566 Class 3 plus - Armourcoat®
<b>TG</b>	<b>SP</b>	Corrosion protection to AS3566 Class 4 plus - Armourcoat® 4
<b>SS</b>	<b>B8</b>	Top Grip®
<b>(CAT 5)</b>		Shank Protector®
		Stainless Steel
		Revolution B8 Corrosion Protection to AS 3566 Class 4
		Suitable for use in ISO 9223 Category 5 Corrosive Environments (Very Severe Marine / Very Severe Industrial)

**COUNTERSUNK RIB HEAD**  
**ZINC YELLOW - SQUARE DRIVE** *For fastening*  
*chipboard, composite board or*  
*timber to timber*



Product Description	Design Features	Pack Quantity	Pack Type	Product Code	Square Driver	Notes
<b>8g</b> - 10 x 20	Zn	1000	Bulk	SCHCQ080202	<b>No 2</b>	
	Zn	100	Trade	SCHCQ080208		
<b>8g</b> - 10 x 25	Zn	1000	Bulk	SCHCQ080252		
	Zn	100	Trade	SCHCQ080258		
<b>8g</b> - 10 x 28	Zn	1000	Bulk	SCHCQ080282		
	Zn	100	Trade	SCHCQ080288		
<b>8g</b> - 10 x 32	Zn	1000	Bulk	SCHCQ080322		
	Zn	100	Trade	SCHCQ080328		
<b>8g</b> - 10 x 35	Zn	1000	Bulk	SCHCQ080352		
	Zn	100	Trade	SCHCQ080358		
<b>8g</b> - 10 x 40	Zn	1000	Bulk	SCHCQ080402		
	Zn	100	Trade	SCHCQ080408		
<b>8g</b> - 10 x 45	Zn	1000	Bulk	SCHCQ080452		
	Zn	100	Trade	SCHCQ080458		
<b>8g</b> - 10 x 50	Zn	1000	Bulk	SCHCQ080502		
	Zn	100	Trade	SCHCQ080508		
<b>8g</b> - 10 x 57	Zn	1000	Bulk	SCHCQ080572		
	Zn	100	Trade	SCHCQ080578		
<b>8g</b> - 10 x 65	Zn	500	Bulk	SCHCQ080652		
	Zn	1000	Bulk	SCHCQ100652		
<b>10g</b> - 8 x 65	Zn	100	Trade	SCHCQ100658	<b>No 2</b>	
	Zn	1000	Bulk	SCHCQ100752		
<b>10g</b> - 8 x 75	Zn	100	Trade	SCHCQ100758		
	Zn	1000	Bulk	SCHCQ101002		
<b>10g</b> - 8 x 100	Zn	100	Trade	SCHCQ101008		



**COUNTERSUNK RIB HEAD  
NEEDLE POINT - PHILLIPS DRIVE**  
*For fastening treated timber to timber*

Product Description	Design Features	Pack Quantity	Pack Type	Product Code	Phillips Driver	Notes
<b>8g</b> - 10 x 25	CL3+, W	1000	Bulk	SCHC3080252	<b>No. 2</b>	
		100	Trade	SCHC3080258		
<b>8g</b> - 10 x 32	CL3+, W	1000	Bulk	SCHC3080322		
		100	Trade	SCHC3080328		
<b>8g</b> - 10 x 35	CL3+, W	1000	Bulk	SCHC3080352		
		100	Trade	SCHC3080358		
<b>8g</b> - 10 x 40	CL3+, W	1000	Bulk	SCHC3080402		
		100	Trade	SCHC3080408		
<b>8g</b> - 10 x 45	CL3+, W	1000	Bulk	SCHC3080452		
		100	Trade	SCHC3080458		
<b>8g</b> - 10 x 50	CL3+, W	1000	Bulk	SCHC3080502		
		100	Trade	SCHC3080508		
<b>8g</b> - 10 x 57	CL3+, W	1000	Bulk	SCHC3080572		
		100	Trade	SCHC3080578		
<b>10g</b> - 8 x 65	CL3+, W	1000	Trade	SCHC3100658	<b>No. 2</b>	
		100	Bulk	SCHC3100752		
<b>10g</b> - 8 x 75	CL3+, W	1000	Trade	SCHC3100758		
		100	Bulk	SCHC3101002		
<b>10g</b> - 8 x 100	CL3+, W	1000	Trade	SCHC3101008		
		100				



**DOUBLE COUNTERSUNK HEAD  
NEEDLE POINT - SQUARE DRIVE**  
*For fastening treated timber to timber*

Product Description	Design Features	Pack Quantity	Pack Type	Product Code	Square Driver	Notes
<b>10g</b> - 11 x 75	CL3+, W	1000	Bulk	SDQC3100752	No. 2	
<b>10g</b> - 11 x 100	CL3+, W	1000	Bulk	SDQC3101002		
<b>10g</b> - 11 x 125	CL3+, W	500	Bulk	SDQC3101252		
<b>10g</b> - 11 x 150	CL3+, W	500	Bulk	SDQC3101502		



**COUNTERSUNK RIB HEAD  
NEEDLE POINT - SQUARE DRIVE**

*For fastening treated timber to timber*



Product Description	Design Features	Pack Quantity	Pack Type	Product Code	Square Driver	Notes
<b>8g</b> - 10 x 25	CL3+, W	1000	Bulk	SCQC3080252	<b>No. 2</b>	
	CL3+, W	100	Trade	SCQC3080258		
<b>8g</b> - 10 x 32	CL3+, W	1000	Bulk	SCQC3080322		
	CL3+, W	100	Trade	SCQC3080328		
<b>8g</b> - 10 x 35	CL3+, W	1000	Bulk	SCQC3080352		
	CL3+, W	100	Trade	SCQC3080358		
<b>8g</b> - 10 x 40	CL3+, W	1000	Bulk	SCQC3080402		
	CL3+, W	100	Trade	SCQC3080408		
<b>8g</b> - 10 x 45	CL3+, W	1000	Bulk	SCQC3080452		
	CL3+, W	100	Trade	SCQC3080458		
<b>8g</b> - 10 x 50	CL3+, W	1000	Bulk	SCQC3080502		
	CL3+, W	100	Trade	SCQC3080508		
<b>8g</b> - 10 x 57	CL3+, W	1000	Bulk	SCQC3080572		
	CL3+, W	100	Trade	SCQC3080578		
<b>10g</b> - 8 x 65	CL3+, W	100	Trade	SCQC3100658	<b>No. 2</b>	
	CL3+, W	1000	Bulk	SCQC3100752		
<b>10g</b> - 8 x 75	CL3+, W	100	Trade	SCQC3100758		
	CL3+, W	1000	Bulk	SCQC3101002		
<b>10g</b> - 8 x 100	CL3+, W	100	Trade	SCQC3101008		

**TYPE 17 - BUGLE HEAD BATTEN**

*For flush fastening of heavy duty treated timbers*



Product Description	Design Features	Pack Quantity	Pack Type	Product Code	Hex Driver Bit	Notes
<b>14g</b> - 10 x 50	CL3+, W	1000	Bulk	SBBC3140502	<b>5mm</b>	
	CL3+, W	100	Trade	SBBC3140508		
<b>14g</b> - 10 x 75	CL3+, W	500	Bulk	SBBC3140752		
	CL3+, W	100	Trade	SBBC3140758		
<b>14g</b> - 10 x 100	CL3+, W	500	Bulk	SBBC3141002		
	CL3+, W	100	Trade	SBBC3141008		
<b>14g</b> - 10 x 150	CL3+, W	250	Bulk	SBBC3141502		



**TYPE 17 - SELF EMBEDDING  
FLOWER HEAD**

*For fastening rigid boards to treated timber*

Product Description	Design Features	Pack Quantity	Product Code	Phillips Driver	Note/Back Type
8g - 18 x 30	Zn	1000	STECZ080302	<b>No. 2</b>	Bulk
8g - 18 x 40	Zn	1000	STECZ080402		Bulk
10g - 12 x 45	Zn	1000	STECZ100452	<b>No. 2</b>	Bulk
	CL3+, W	1000	STEC3100452		Bulk



**WING DRILLER  
COUNTERSUNK RIB HEAD**

*For flush fastening treated timber to metal*

Product Description	Design Features	Pack Quantity	Pack Type	Product Code	Phillips Driver	Notes
6g - 20 x 50	Zn	1000	Bulk	SWRCZ060502	<b>No. 2</b>	
	Zn	100	Trade	SWRCZ060508		
	CL3+, W	1000	Bulk	SWRC3060502		
10g - 16 x 35	Zn	500	Bulk	SWRCZ100352	<b>No. 2</b>	
	Zn	100	Trade	SWRCZ100358		
10g - 16 x 40	CL3+, W	500	Bulk	SWRC3100402		
	Zn	500	Bulk	SWRCZ100452		
10g - 16 x 45	Zn	100	Trade	SWRCZ100458		
	CL3+, W	500	Bulk	SWRC3100452		
	CL3+, W	100	Trade	SWRC3100458		
	Zn	500	Bulk	SWRCZ100502		
	Zn	100	Trade	SWRCZ100508		
50 10g - 16 x 55	Zn	1000	Bulk	SWRCZ100552		
	Zn	100	Trade	SWRCZ100558		
	CL3+, W	1000	Bulk	SWRC3100552		
	Zn	1000	Trade	SWRCZ100602		
10g - 16 x 60	Zn	500	Bulk	SWRCZ100702		
10g - 16 x 70	Zn	100	Trade	SWRCZ100708		
	Zn	1000	Bulk	SWRCZ100752		
10g - 16 x 75	Zn	100	Trade	SWRCZ100758		
	CL3+, W	1000	Bulk	SWRC3100752		
	CL3+, W	500	Bulk	SWRC3140652		
	CL4+, W	500	Bulk	SWRC4140652		
14g - 20 x 65	CL4+, W	500	Bulk	SWRC4140752	<b>No. 3</b>	
	CL4+, W	250	Bulk	SWRC4140952		
14g - 20 x 75	CL4+, W	250	Bulk	SWRC4141152		
14g - 20 x 95						
14g - 20 x 115						

**Please Note**

When Moisture Content of treated Pine exceeds 10% use 12g screws minimum.



**BUGLE HEAD - NEEDLE POINT  
ZINC YELLOW**

*For fastening plasterboard to timber  
and thin steel up to 0.6mm thick*



Product Description	Design Features	Pack Quantity	Pack Type	Product Code	Phillips Driver	Notes
<b>6g</b> - 9 x 25	Zn	1000	Bulk	SDYRZ060252	<b>No. 2</b>	
	Zn	100	Trade	SDYRZ060258		
<b>6g</b> - 9 x 30	Zn	1000	Bulk	SDYRZ060302		
	Zn	100	Trade	SDYRZ060308		
<b>6g</b> - 18 x 25	Zn	11000	Mega	SDY CZ06025B		
	Zn	1000	Bulk	SDY CZ060252		
<b>6g</b> - 18 x 30	Zn	100	Trade	SDY CZ060258		
	Zn	1000	Bulk	SDY CZ060302		
<b>6g</b> - 18 x 40	Zn	100	Trade	SDY CZ060308		
	Zn	1000	Bulk	SDY CZ060402		
<b>6g</b> - 18 x 45	Zn	100	Trade	SDY CZ060408		
	Zn	1000	Bulk	SDY CZ060452		
<b>7g</b> - 16 x 20	Zn	100	Trade	SDY CZ060458		
	Zn	1000	Bulk	SDY CZ070202		
<b>7g</b> - 16 x 25	Zn	1000	Bulk	SDY CZ070252	<b>No. 2</b>	
	Zn	1000	Bulk	SDY CZ070302		
<b>7g</b> - 16 x 30	Zn	1000	Bulk	SDY CZ070402		
	Zn	1000	Bulk	SDY CZ070452		
<b>7g</b> - 16 x 40	Zn	500	Bulk	SDY CZ070502		
	Zn	100	Trade	SDY CZ070508		
<b>7g</b> - 16 x 50	Zn	1000	Bulk	SDY CZ070552		
	Zn	1000	Bulk	SDYRZ080252		
<b>8g</b> - 10 x 25	Zn	1000	Bulk	SDYRZ080302	<b>No. 2</b>	
	Zn	1000	Bulk	SDYRZ080402		
<b>8g</b> - 10 x 30	Zn	1000	Bulk	SDYRZ080452		
	Zn	1000	Bulk	SDYRZ080502		
<b>8g</b> - 10 x 40	Zn	500	Bulk	SDY CZ080502		
	Zn	1000	Bulk	SDY CZ080602		
<b>8g</b> - 10 x 50	Zn	100	Trade	SDY CZ080608		
	Zn	1000	Bulk	SDY CZ080652		
<b>8g</b> - 15 x 50	Zn	100	Trade	SDY CZ080658		
	Zn	500	Bulk	SDY CZ080752		
<b>8g</b> - 15 x 60	Zn	100	Trade	SDY CZ080758		
	Zn	1000	Bulk	SDY CZ080852		
<b>8g</b> - 15 x 65	Zn	100	Trade	SDY CZ080858		
	Zn	500	Bulk	SDY CZ080952		
<b>8g</b> - 15 x 75	Zn	100	Trade	SDY CZ080958		
	Zn	1000	Bulk	SDY CZ081052		



**BUGLE HEAD  
ZINC YELLOW**

*For fastening plasterboard to steel up to 2mm thick*

Product Description	Design Features	Pack Quantity	Pack Type	Product Code	Phillips Driver	Notes
<b>6g</b> - 18 x 25	Zn	1000	Bulk	SMUCZ060252	<b>No.2</b>	
	Zn	100	Trade	SMUCZ060258		
<b>6g</b> - 18 x 30	Zn	1000	Bulk	SMUCZ060302		
	Zn	100	Trade	SMUCZ060308		
<b>6g</b> - 18 x 45	Zn	1000	Bulk	SMUCZ060452		
	Zn	100	Trade	SMUCZ060458		



**BUGLE HEAD - NEEDLE POINT  
BLACK PHOSPHATE**

*For fastening plasterboard to timber and thin steel up to 0.6mm thick*

Product Description	Design Features	Pack Quantity	Pack Type	Product Code	Phillips Driver	Notes
<b>6g</b> - 18 x 25	Black Phos	10000	Mega	SDYCP06025B	<b>No.2</b>	



**LAMINATING SCREWS  
BUGLE HEAD - NEEDLE POINT**

*For fastening multiple layers of plasterboard to timber and thin steel up to 0.6mm thick*

Product Description	Design Features	Pack Quantity	Pack Type	Product Code	Phillips Driver	Notes
<b>10g</b> - 8 x 38	Zn	1000	Bulk	SDYRZ100382	<b>No.2</b>	
	Zn	100	Trade	SDYRZ100388		
<b>10g</b> - 8 x 50	Zn	1000	Bulk	SDYRZ100502		

## PRODUCT FEATURE KEY

<b>W</b>	<b>Zn</b>	Covered by the Bremick Warranty
<b>CL3+</b>		Zinc Yellow
<b>CL4+</b>		Corrosion protection to AS3566 Class 3 plus - Armourcoat®
<b>TG</b>	<b>SP</b>	Corrosion protection to AS3566 Class 4 plus - Armourcoat® 4
<b>SS</b>	<b>B8</b>	Top Grip®
<b>(CAT 5)</b>		Shank Protector®
		Stainless Steel
		Revolution B8 Corrosion Protection to AS 3566 Class 4
		Suitable for use in ISO 9223 Category 5 Corrosive Environments (Very Severe Marine / Very Severe Industrial)



## BUTTON HEAD - NEEDLE POINT

*For fastening into timber & thin steel where a large low profile head is required*



Product Description	Design Features	Pack Quantity	Pack Type	Product Code	Phillips Driver	Notes
<b>8g</b> - 15 x 12	Zn	1000	Bulk	SNBCZ080122	<b>No. 2</b>	
	Zn	100	Trade	SNBCZ080128		
	CL3+,W	1000	Bulk	SNBC3080122		
	CL3+,W	100	Trade	SNBC3080128		
<b>8g</b> - 15 x 15	Zn	1000	Bulk	SNBCZ080152		
	Zn	100	Trade	SNBCZ080158		
	CL3+,W	1000	Bulk	SNBC3080152		
	CL3+,W	100	Trade	SNBC3080158		
<b>8g</b> - 15 x 20	Zn	1000	Bulk	SNBCZ080202		
	Zn	100	Trade	SNBCZ080208		
	CL3+,W	1000	Bulk	SNBC3080202		
	CL3+,W	100	Trade	SNBC3080208		
<b>8g</b> - 15 x 25	Zn	1000	Bulk	SNBCZ080252		
	Zn	100	Trade	SNBCZ080258		
	CL3+,W	1000	Bulk	SNBC3080252		
	CL3+,W	100	Trade	SNBC3080258		
<b>8g</b> - 15 x 30	Zn	1000	Bulk	SNBCZ080302		
	Zn	100	Trade	SNBCZ080308		
	CL3+,W	1000	Bulk	SNBC3080302		
	CL3+,W	100	Trade	SNBC3080308		

## PRODUCT FEATURE KEY

- W Zn** Covered by the Bremick Warranty
- CL3+** Zinc Yellow
- CL4+** Corrosion protection to AS3566 Class 3 plus - Armourcoat®
- TG SP** Corrosion protection to AS3566 Class 4 plus - Armourcoat® 4
- SS B8** Top Grip®
- (CAT 5)** Shank Protector®
- Stainless Steel
- Revolution B8 Corrosion Protection to AS 3566 Class 4
- Suitable for use in ISO 9223 Category 5 Corrosive Environments (Very Severe Marine / Very Severe Industrial)



## BUGLE HEAD - NEEDLE POINT

ZINC YELLOW

*For fastening to both timber and thin steel*

Product Description	Design Features	Pack Quantity	Pack Type	Product Code	Phillips Driver	Notes
<b>6g</b> - 9 x 25	Zn	1000	Bulk	SDYRZ060252	<b>No. 2</b>	
	Zn	100	Trade	SDYRZ060258		
<b>6g</b> - 9 x 30	Zn	1000	Bulk	SDYRZ060302		
	Zn	100	Trade	SDYRZ060308		
<b>6g</b> - 18 x 25	Zn	11000	Mega	SDYCZ06025B		
	Zn	1000	Bulk	SDYCZ060252		
	Zn	100	Trade	SDYCZ060258		
<b>6g</b> - 18 x 30	Zn	1000	Bulk	SDYCZ060302		
	Zn	100	Trade	SDYCZ060308		
<b>6g</b> - 18 x 40	Zn	1000	Bulk	SDYCZ060402		
	Zn	100	Trade	SDYCZ060408		
<b>6g</b> - 18 x 45	Zn	1000	Bulk	SDYCZ060452		
	Zn	100	Trade	SDYCZ060458		
<b>7g</b> - 16 x 20	Zn	1000	Bulk	SDYCZ070202	<b>No. 2</b>	
	Zn	1000	Bulk	SDYCZ070252		
<b>7g</b> - 16 x 25	Zn	1000	Bulk	SDYCZ070302		
	Zn	1000	Bulk	SDYCZ070452		
<b>7g</b> - 16 x 45	Zn	1000	Bulk	SDYCZ070502		
	Zn	100	Trade	SDYCZ070508		
<b>7g</b> - 16 x 50	Zn	1000	Bulk	SDYRZ080252	<b>No. 2</b>	
	Zn	1000	Bulk	SDYRZ080302		
<b>8g</b> - 10 x 25	Zn	1000	Bulk	SDYRZ080402		
	Zn	1000	Bulk	SDYRZ080452		
<b>8g</b> - 10 x 40	Zn	1000	Bulk	SDYRZ080502		
	Zn	1000	Bulk	SDYCZ080502		
<b>8g</b> - 10 x 50	Zn	1000	Bulk	SDYCZ080602		
	Zn	100	Trade	SDYCZ080608		
<b>8g</b> - 15 x 50	Zn	1000	Bulk	SDYCZ080652		
	Zn	100	Trade	SDYCZ080658		
<b>8g</b> - 15 x 65	Zn	1000	Bulk	SDYCZ080752		
	Zn	100	Trade	SDYCZ080758		

## GENERAL PURPOSE SCREWS

65

## PAN HEAD - NEEDLE POINT

*For general fastening to both timber & thin steel*

Product Description	Design Features	Pack Quantity	Pack Type	Product Code	Phillips Driver	Notes
<b>7g</b> - 16 x 20	Zn	1000	Bulk	SNPCZ070202	<b>No.2</b>	
<b>7g</b> - 16 x 25	Zn	1000	Bulk	SNPCZ070252		
<b>7g</b> - 16 x 30	Zn	1000	Bulk	SNPCZ070302		
<b>7g</b> - 16 x 40	Zn	1000	Bulk	SNPCZ070402		

## COUNTERSUNK RIB HEAD - NEEDLE POINT

*For fastening Villaboard Sheets to timber and thin steel up to 0.6mm thick*

Product Description	Design Features	Pack Quantity	Pack Type	Product Code	Phillips Driver	Notes
<b>8g</b> - 15 x 20	Zn	1000	Bulk	SVICZ080202	<b>No.2</b>	
	Zn	100	Trade	SVICZ080208		
<b>8g</b> - 15 x 30	Zn	1000	Bulk	SVICZ080302		
	Zn	100	Trade	SVICZ080308		
<b>8g</b> - 15 x 50	Zn	1000	Bulk	SVICZ080502		

## PRODUCT FEATURE KEY

<b>W</b>	<b>Zn</b>	Covered by the Bremick Warranty
<b>CL3+</b>		Zinc Yellow
<b>CL4+</b>		Corrosion protection to AS3566 Class 3 plus - Armourcoat®
<b>TG</b>	<b>SP</b>	Corrosion protection to AS3566 Class 4 plus - Armourcoat® 4
<b>SS</b>	<b>B8</b>	Top Grip®
<b>(CAT 5)</b>		Shank Protector®
		Stainless Steel
		Revolution B8 Corrosion Protection to AS 3566 Class 4
		Suitable for use in ISO 9223 Category 5 Corrosive Environments (Very Severe Marine / Very Severe Industrial)



We are pleased to announce the introduction of a new range of collated self drilling screws specifically developed for interior finishing trades. Including a full offering of collated dry wall and Villaboard screws suitable for use with:

Makita, Senco, Hilti, Airco, Hitachi and most other collated screw guns.



**COLLATED PLASTERBOARD SCREWS**  
STRIPS OF 50 SCREWS  
BUGLE HEAD - NEEDLE POINT - FINE THREAD  
ZINC YELLOW

*For fastening plasterboard to timber and thin steel up to 0.6mm thick.*

Product Description	Design Features	Pack Quantity	Pack Type	Product Code	Phillips Driver	Notes
6g - 18 x 25	Zn	1000	Bulk	SDYCZ06025C	No.2	
6g - 18 x 30	Zn	1000	Bulk	SDYCZ06030C		
6g - 18 x 40	Zn	1000	Bulk	SDYCZ06040C		
6g - 16 x 50	Zn	1000	Bulk	SDYCZ07050C		



**COLLATED PLASTERBOARD SCREWS**  
STRIPS OF 50 SCREWS  
BUGLE HEAD - NEEDLE POINT - COARSE THREAD  
ZINC YELLOW

*For fastening plasterboard to timber.*

Product Description	Design Features	Pack Quantity	Pack Type	Product Code	Phillips Driver	Notes
6g - 9 x 25	Zn	1000	Bulk	SDYRZ06025C	No.2	
6g - 9 x 30	Zn	1000	Bulk	SDYRZ06030C		
6g - 9 x 40	Zn	1000	Bulk	SDYRZ06040C		



**COLLATED PLASTERBOARD SCREWS**

**STRIPS OF 50 SCREWS**  
**BUGLE HEAD - METAL DRILLER -**  
**COARSE THREAD - ZINC YELLOW**

*For fastening plasterboard to steel  
 up to 2.0mm thick.*



Product Description	Design Features	Pack Quantity	Pack Type	Product Code	Phillips Driver	Notes
6g - 18 x 25	Zn	1000	Bulk	SMUCZ06025C	<b>No.2</b>	
6g - 18 x 30	Zn	1000	Bulk	SMUCZ06030C		
6g - 18 x 45	Zn	1000	Bulk	SMUCZ06045C		

**COLLATED PLASTERBOARD SCREWS**

**STRIPS OF 50 SCREWS**  
**COUNTERSUNK RIB HEAD - METAL DRILLER**  
**ZINC YELLOW**

*For fastening Villaboard sheets to steel  
 up to 3.0 mm thick.*



Product Description	Design Features	Pack Quantity	Pack Type	Product Code	Phillips Driver	Notes
8g - 18 x 20	Zn	1000	Bulk	SMRCZ08020C	<b>No.2</b>	
8g - 18 x 30	Zn	1000	Bulk	SMRCZ08030C		

**COLLATED PLASTERBOARD SCREWS**

**STRIPS OF 50 SCREWS**  
**COUNTERSUNK RIB HEAD - NEEDLE POINT**  
**ZINC YELLOW**

*For fastening Villaboard sheets to timber and steel  
 up to 0.6mm thick.*

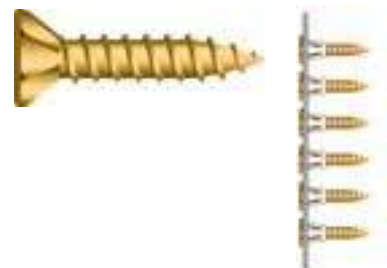

Product Description	Design Features	Pack Quantity	Pack Type	Product Code	Phillips Driver	Notes
8g - 15 x 20	Zn	1000	Bulk	SVICZ08020C	<b>No.2</b>	
8g - 15 x 30	Zn	1000	Bulk	SVICZ08030C		

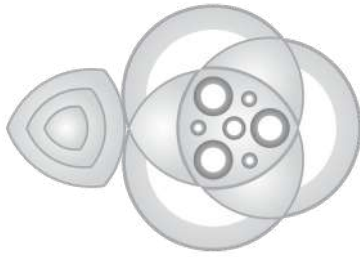

**KEW® UNIVERSAL INSULATION DISC  
PLASTIC 84mm DIAMETER DISC WITH CAP**

*Used in conjunction with self drilling screws (6g to 14g) for fastening rigid board or soft insulation to timber.*

Product Description	Design Features	Pack Quantity	Pack Type	Product Code	Notes
84mm Diameter	Plastic	200	Bulk	KEWUDS84000	

*Can also be used for fastening insulation to masonry & concrete, refer to Bremick Masonry Anchor Catalogue for details.*



**INSULATION DISC  
PLASTIC 50mm DIAMETER DISC**

*Used in conjunction with 10g self drilling screws for fastening rigid insulation boards to timber.*

Product Description	Design Features	Pack Quantity	Pack Type	Product Code	Notes
50mm Diameter	Plastic	200	Bulk		



**DOUBLE COUNTERSUNK HEAD  
NEEDLE POINT - SQUARE DRIVE**

*For use with insulation discs to fasten insulation materials to timber*

Product Description	Design Features	Pack Quantity	Pack Type	Product Code	Square Driver	Notes
10g - 11 x 75	CL3+, W	1000	Bulk	SDQC3100752	No. 2	
10g - 11 x 100	CL3+, W	1000	Bulk	SDQC3101002		
10g - 11 x 125	CL3+, W	500	Bulk	SDQC3101252		
10g - 11 x 150	CL3+, W	500	Bulk	SDQC3101502		

**APPLICATIONS**

Used together with self drilling screws to fasten:

- Thermal Insulation
- Acoustic Insulation
- Sheeting membranes
- Foils
- Mesh Fabrics

**SETTING INSTRUCTIONS**

**Fastening to Timber**

**1: Insert**

Insert self drilling screw through pre-formed hole in insulation disc, and push into insulation.



**2: Tighten**

Drive self drilling screw into base material until screw head is tight & flush with insulation disc.



**3: Finish**

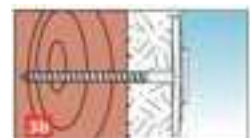

**SEALING WASHERS - EPDM SEAL**

*For assembly onto Bremick Self Drilling Screws  
Non Conductive EPDM*



Product Description	Pack Quantity	Pack Type	Product Code	Notes
<b>8g</b>	1000	Bulk	SEALA080002	
<b>10g</b>	1000	Bulk	SEALA100002	
<b>12g</b>	1000	Bulk	SEALA120002	
<b>14g</b>	1000	Bulk	SEALA140002	

**BONDED WASHER - ALUMINIUM / EPDM SEAL**

*Aluminium 5251 - Non Conductive EPDM*



Product Description	Pack Quantity	Pack Type	Product Code	Notes
<b>12g</b> - 16mm O.D x 0.9mm	1000	Bulk	SEALB120162	
<b>14g</b> - 16mm O.D x 0.9mm	1000	Bulk	SEALF140162	
<b>14g</b> - 19mm O.D x 1.2mm	1000	Bulk	SEALF140192	
<b>14g</b> - 25mm O.D x 1.2mm	1000	Bulk	SEALF140252	

**POLYCARBONATE - EPDM SEAL**

*For use with polycarbonate sheeting  
Non Conductive EPDM*



Product Description	Pack Quantity	Pack Type	Product Code	Notes
<b>12/14g</b> - 23mm	1000	Bulk	SEALP120002	

**WEATHERSEAL WASHERS**

*For fibre glass profiles*



Product Description	Pack Quantity	Pack Type	Product Code	Notes
<b>12/14g</b> - 32mm	1000	Bulk	SEALG120002	



**CYCLONE PLATE - CUSTOM ORB®**

Product Description	Pack Quantity	Pack Type	Product Code	Notes
14g	500	Bulk	PLATA14CST2	



**CYCLONE PLATE - TRIMDEK® / SPANDEK®**

Product Description	Pack Quantity	Pack Type	Product Code	Notes
14g	500	Bulk	PLATA14TRM2	



**CYCLONE PLATE - KLIPLOK®**

Product Description	Pack Quantity	Pack Type	Product Code	Notes
14g	500	Bulk	PLATA14KLP2	



**CYCLONE PLATE - KING KLIP®**

Product Description	Pack Quantity	Pack Type	Product Code	Notes
14g	500	Bulk	PLATA14FKK2	



**CYCLONE SEAL - CUSTOM ORB®**

*Non Conductive EPDM*

Product Description	Pack Quantity	Pack Type	Product Code	Notes
14g - 18mm O.D.	500	Bulk	SEALC14CST2	



**CYCLONE SEAL - KLIPLOK®**

*Non Conductive EPDM*

Product Description	Pack Quantity	Pack Type	Product Code	Notes
14g - 30mm O.D.	500	Bulk	SEALC14KLP2	



**CYCLONE SEAL - TRIMDEK / SPANDEK®**

*Non Conductive EPDM*

Product Description	Pack Quantity	Pack Type	Product Code	Notes
14g - 36mm O.D.	500	Bulk	SEALC14TRM2	



**CYCLONE SEAL - KINGKLIP®**

*Non Conductive EPDM*

Product Description	Pack Quantity	Pack Type	Product Code	Notes
14g	500	Bulk	SEALC14KLP2	

CUSTOM ORB®, TRIMDEK®, SPANDEK and KLIPLOK are registered trade marks of BlueScope Steel Limited.

**HEXAGON SOCKETS**

*For use with hexagonal head self drilling screws*



Product Description	Pack Quantity	Pack Type	Product Code	Notes
<b>1/4</b> - 45mm	10	Bulk	TSKIP060452	
	1 x 5	Card	TSKIP06045C	
<b>5/16</b> - 69mm	10	Bulk	TSKIP080692	
	1 x 5	Card	TSKIP08069C	
<b>3/8</b> - 69mm	10	Bulk	TSKIP100692	
	1 x 5	Card	TSKIP10069C	

**HEXAGON DRIVE BITS**

*For use with hexagon recessed self drilling screws, eg. Bugle Batten screws*



Product Description	Pack Quantity	Pack Type	Product Code	Notes
<b>5mm</b> - 32mm	10	Bulk	TDBMP050322	
<b>5mm</b> - 50mm	10	Bulk	TDBMP050502	

**PHILLIPS DRIVE BITS - SINGLE ENDED**

*For use with Phillips recessed self drilling screws*



Product Description	Pack Quantity	Pack Type	Product Code	Notes
<b>1</b> - 50mm	10	Bulk	TSXMP010502	
<b>2</b> - 25mm	10	Bulk	TSXMP020252	
	10	Bulk	TSXMP020502	
<b>2</b> - 50mm	1 x 5	Card	TSXMP02050C	
	10	Bulk	TSXMP020752	
<b>2</b> - 75mm	1 x 5	Card	TSXMP02075C	
	10	Bulk	TSXMP021502	
<b>2</b> - 150mm	1 x 5	Card	TSXMP02150C	
	10	Bulk	TSXMP030502	
<b>3</b> - 50mm				



### PHILLIPS DRIVE BITS - DOUBLE ENDED

*For use with Phillips recessed self drilling screws*

Product Description	Pack Quantity	Pack Type	Product Code	Notes
<b>2</b> - 45mm	10	Bulk		
	1 x 5	Card	TDXMP020452	
<b>2</b> - 65mm	10	Bulk	TDXMP02045C	
	1 x 5	Card	TDXMP020652	
<b>2</b> - 100mm	10	Bulk	TDXMP02065C	
	1 x 5	Card	TDXMP021002	
			TDXMP02100C	



### MAGNETIC BIT HOLDER

*For quick changing drive bits and for insert bit adaption to power screw drivers*

Product Description	Pack Quantity	Pack Type	Product Code	Notes
<b>1/4</b> - 65mm x 75mm	10	Bulk	TMBMP000752	



### SQUARE DRIVE BITS

*For use with square drive recessed self drilling screws*

Product Description	Pack Quantity	Pack Type	Product Code	Notes
<b>No.2</b> x 50mm	10	Bulk	TDQMP020502	



### TRILOBULAR DRIVE BIT

*For use with Trilobular recessed self drilling screws, eg. Tamper Proof screws*

Product Description	Pack Quantity	Pack Type	Product Code	Notes
<b>4.06</b> x 25mm	10	Bulk	TSTMP000252	



## For Retail Display of Bremick Trade Packs

For effective display of our new range of Trade Packs Bremick now stocks a purpose designed Retail Display Stand that has been structurally reinforced to carry up to 120 KG per Shelf.

The modular design has been carefully matched to the Bremick Trade Pack dimensions to give maximum shelf densities and is the perfect display unit for the new plastic trade packs.



### RETAIL DISPLAY STAND

*For retail display of Bremick Trade Products*

Height (mm)	Width (mm)	Shelf Depth (mm)	Product Code	Pack Qty	Notes
1800	1200	N/A	TRADESTAND1	1	

(PRODUCTS NOT INCLUDED)

### SHELF UNITS

*Includes a steel shelf & 2 multi Brackets*

Height (mm)	Width (mm)	Shelf Depth (mm)	Product Code	Pack Qty	Notes
N/A	1200	400	TRADESHELF1	1	

(PRODUCTS NOT INCLUDED)



## SILICONE SEALANT ROOFING AND GUTTERING

*For sealing and waterproofing*

Product Description	Colour	Pack Quantity	Pack Type	Product Code	Notes
SILICONE SEAL ROOF/GUTTER 300ml	Translucent	20	Bulk	CSSRGTR3002	
SILICONE SEAL ROOF/GUTTER 300ml	Grey	20	Bulk	CSSRGGR3002	
SILICONE SEAL ROOF/GUTTER 300ml	Black	20	Bulk	CSSRGL3002	
SILICONE SEAL ROOF/GUTTER 300ml	White	20	Bulk	CSSRGWH3002	
SILICONE SEAL ROOF/GUTTER 300ml Aluminium/Silver		20	Bulk	CSSRGS3002	

2 mixer nozzles supplied with each cartridge



## ACRYLIC GAP FILLER

*General purpose non shrink gap filler*

Product Description	Colour	Pack Quantity	Pack Type	Product Code	Notes
ACRYLIC GAP FILLER 300ml	White	20	Bulk	CFAGFWH3002	

2 mixer nozzles supplied with each cartridge



## DISPENSING HAND GUN (CAULKING GUN) HEAVY DUTY

*For use with 300ml Cartridges*

Product Description	Pack Quantity	Product Code	Notes
Cartridge Dispensing Hand Gun (To suit Bremseal & Bremgap 300ml cartridges)	1	TMACISF4002	
Mixer Nozzels	50	CMIXN503002	



<b>SELF DRILLING SCREW SELECTION</b>	<b>96</b>
Screw Designations	96
Head Styles	97
Drilling Point Styles	98
Fastening to Metal – Screw Selection	99
Drilling Capacities & Thread Characteristics	100
Screw Designations	100
Fastening to Timber – Screw Selection	101
Wing Drillers – Screw Selection	102
Fastening Roof Sheeting To Metal	103
Fastening Roof Sheeting To Timber	105
Fastening Roof Sheeting in Cyclonic Areas	107
<b>MECHANICAL PROPERTIES</b>	<b>115</b>
Mechanical Properties	115
Axial Withdrawal Capacities	118
Sealing Washers	122
<b>BREMICK PRODUCT CODES</b>	<b>123</b>
Product Coding System	123



For ease of identification all Bremick Self Drilling screws conform to the following designations:

- The first character denotes the Screw Gauge.
- The second character denotes the Threads Per Inch (TPI).
- The third character denotes the screw length.

### FASTENER GAUGE (g)

The screw Gauge is determined by the major (outside) thread diameter.

The relationship of Gauge and Diameter of Bremick Screws is Shown below:

TABLE 1

Gauge	Major Diameter	AS 3566
6g	3.5mm	ST 3.5 (No6)
7g	3.9mm	ST 3.9 (No7)
8g	4.2mm	ST 4.2 (No8)
10g	4.8mm	ST 4.8 (No10)
12g	5.5mm	ST 5.5 (No12)
14g	6.3mm	ST 6.3 (No14)

All dimensions are nominal.

### THREADS PER INCH (TPI)

The TPI of a screw is defined by the number of Screw Threads per inch (25.4mm)

### SCREW LENGTH (mm)

The screw length is defined as the total length of penetration.

For screw type designed to give a raised head,

eg.

- Hexagonal Headed Screws
- Wafer Headed Screws
- Pan Head Screws
- Button Head Screws

The length is measured from the underside of the head to the end of the drilling point.

For screw types designed to give a flush head,

- Bugle Headed Screws
- Self Embedding Head Screws

eg. Countersunk Screws

The length is measured from the top of the head to the end of the drill point.

### EXAMPLE

**12 - 11 x 45**







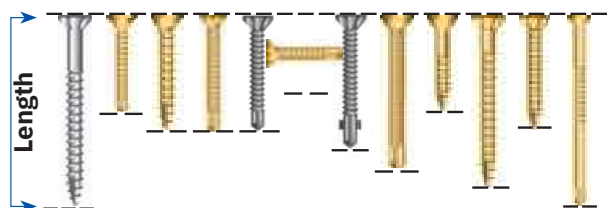
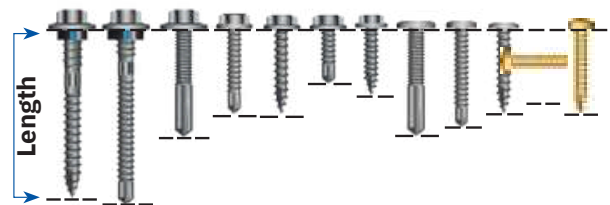
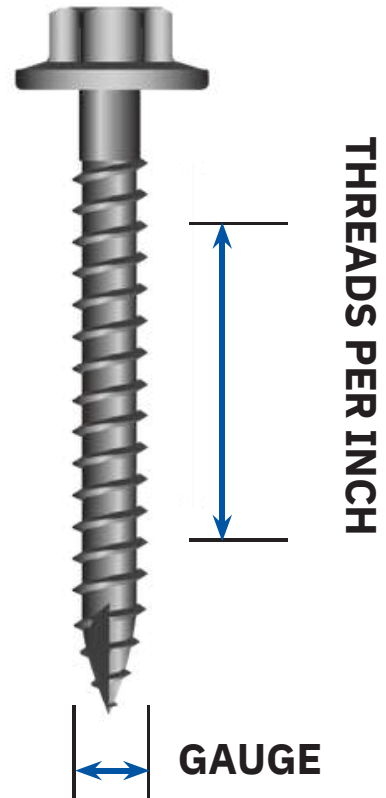



12g - Screw Gauge

45mm - Screw Length











11 - Threads Per Inch (TPI)



**RAISED HEAD DESIGNS**

		<b>HEXAGONAL WASHER HEAD</b> Hexagonal head with an integral fl at washer recessed to accommodate a resilient sealing washer. Available in 1/4", 5/16" and 3/8" sizes. The washer surface also provides a bearing surface for the drive socket. Drive with a hexagonal socket driver.
		<b>WAFER HEAD</b> Low profile rounded head giving optimal load bearing in situations where there is restricted head room, eg. fastening of concealed clips. Driven with a Phillips #2 Cross Recess Bit.
		<b>PAN HEAD</b> Rounded head with a fl at underside that optimises clamping forces when used in metal sheeting applications.
		<b>BUTTON HEAD</b> Very low profile head of large diameter with a fl at underside to optimise fastening to thin sheet metals and drywall tracks. The low profile head permits overlaying of board and plasterboard without affecting seating. Drive with a Phillips #2 Cross Recess Bit.
		<b>FLAT HEAD</b> Extremely low profile head with broad bearing surface primarily used to fasten thin metal sections eg. studwork. The extremely low head permits overlaying with plaster board or other lining materials without affecting seating.

**FLUSH HEAD DESIGNS**

		<b>COUNTERSUNK HEAD</b> Developed to give a flush finish when fastening timber and is also used for other applications requiring a flush or recess finish such as mounting hinges. Will require countersinking.
		<b>COUNTERSUNK RIBBED HEAD</b> Countersunk head with reaming cutters on the underside to assist self embedment into timber and soft board materials. Drive with a Phillips #2 Cross Recess Bit, or a Square Drive #2 Bit.
		<b>SELF EMBEDDING (FLOWER) HEAD</b> A special flat head featuring reaming cutters and flutes for self embedding into fibre cement sheets resulting in a flush finish. Drive with a Phillips #2 Cross Recess Bit.
		<b>BUGLE BATTEN HEAD</b> A countersunk head specifically designed to embed into timber for heavy duty fastening of timber battens and boardwalks. Drive with a 5mm Internal Hexagonal drive bit.
		<b>BUGLE HEAD</b> A countersunk head specifically designed to give flush fastening in plasterboard without tearing the facing paper. Drive with a #2 Phillips Cross Recess Bit.





## DRILL POINTS

**UNIVERSAL DRILL POINT**

Universal drill points are designed to drill through both timber and metal giving exceptional performance in softwood, thin metal battens and steel up to 1.9mm thick.

**METAL DRILLING POINT – Drill points No.2, No.3 & No4**

A twist drill style hardened point for drilling through steel up to 6.4mm thick. The length of the drilling flutes determine the amount of drilling swarf that can be expelled and therefore the depth of metal that can be drilled.

**DEEP DRILLING POINT – Drill points No.5**

A twist drill style hardened point for drilling through steel up to 12.5mm thick.



Extended swarf clearing flutes ensure efficient drilling without fouling the head seating with drilling debris.

**WING DRILLING POINT – Drill points No.2, No.3 & No4**

Self drilling twist drill style point that is designed for fastening in to metal base materials up to 6.4mm thick. The screw design incorporates two cutting wings that ream a thread clearance hole through the timber preventing the timber “lifting” as the screw point penetrated the base material. After cutting the clearance hole in the timber the wings break off as they contact the metal base material allowing the screw threads to tap into the metal. When selecting the length of a Wing Drilling Screw ensure that the selected screw is at least 20mm longer than the timber thickness to allow for the long drilling point.

**TIMBER DRILLING POINT – Drill point TYPE 17**

A self drilling point for fastening in to timber. The hardened point will also drill through thin metals up to 0.75mm thick that makes this point suitable for fastening roofing sheets to timber battens. The screw threads extend down the point thus the screw “puts” itself into the timber that reduces the required drilling pressure and reduces the risk of stripping of threads due to “over running”.

**NEEDLE POINT**

A self drilling point designed to pierce through thin metals into timber and lap and stitch fastening thin sheets with maximum base materials thickness (BMT) of 0.6mm.

**CONE POINT**

A conical point used on self tapping fasteners which is heavily tapered to assist thread tapping into predrilled holes in metal substrates.



## SCREW SELECTION - METAL

Bremick Self Drilling Screws for metal are designed and manufactured to exceed the specified performance requirements of Australian Standard 3566 – Self drilling screws for the building and construction industries.

Each metal drilling screw is designed to provide optimum performance matching of drill point diameter and thread configuration ensuring maximum thread engagement into the specified metal base materials.



When installed in accordance with the basic installation recommendations Bremick metal drilling screws will provide drilling speed similar to that of High speed Steel twist drills and secure thread engagement resulting in a highly efficient one step fastening into mild and high tensile metals.

## METAL DRILLING SCREW SELECTION

When selecting metal drilling screws for a specific application the following selection criteria should be followed;

### 1: HEAD STYLE

Select the Head Style most appropriate for the intended application.

### 2: DRILLING CAPACITY

Measure the total thickness of the metal base material and select a screw with a drilling capacity suitable for the intended application.

### 3: SCREW LENGTH

Measure the combined thickness of the material to be fastened and the base material thickness and select a screw long enough to permit at least 3 protruding threads.

### 4: PROTECTIVE COATING

Select a corrosion protection system suitable for the intended environmental conditions.

### 5: MECHANICAL PROPERTIES

Check that the mechanical properties of the selected fastener meet the loading requirements of the intended application.

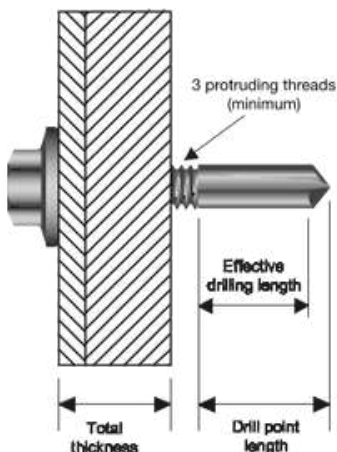

## INSTALLATION STAGES METAL DRILLING SCREWS

### STAGE 1

Drill point starts penetration. Drill speed, 2200 – 2500 rpm

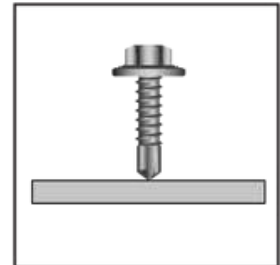

### STAGE 2

Drill point penetrates through steel

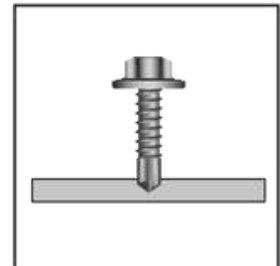

### STAGE 3

Drill point must clear steel prior to thread engagement

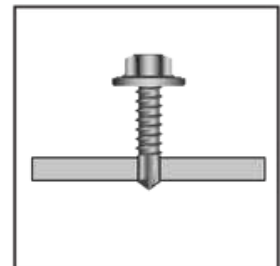

### STAGE 4

Screw taps threads into steel drawing materials together to generate the clamping force.

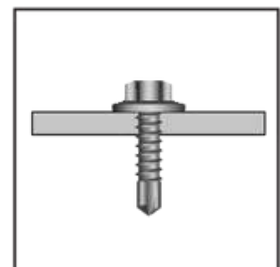



### DRILLING CAPACITIES AND THREAD CHARACTERISTICS BREMICK SELF DRILLING SCREWS FOR METAL

TABLE 2

Screw Type	AS 3566-2002 Size Designation	Size	Screw Gauge	Threads Per Inch TPI	Major Diameter (Nominal)	Drilling Capacity (Maximum)
Self Drilling Metal	ST 3.5 (No 6)	6-18	6g	18	3.5mm	2.0mm
Self Drilling Metal	ST 3.5 (No 6)	6-20	6g	20	3.5mm	2.4mm
Self Drilling Metal	ST 4.2 (No 8)	8-18	8g	18	4.2mm	2.5mm
Self Drilling Metal	ST 4.8 (No 10)	10-16	10g	16	4.8mm	4.5mm
Self Drilling Metal	ST 4.8 (No 10)	10-24	10g	24	4.8mm	4.5mm
Self Drilling Metal	ST 5.5 (No 12)	12-11	12g	11	5.5mm	2.0mm
Self Drilling Metal	ST 5.5 (No 12)	12-14	12g	14	5.5mm	5.5mm
Self Drilling Metal	ST 5.5 (No 12)	12-24	12g	24	5.5mm	6.5mm
Self Drilling Metal	ST 6.3 (No 14)	14-10	14g	10	6.3mm	5.0mm
Self Drilling Metal	ST 6.3 (No 14)	14-14	14g	14	6.3mm	6.5mm
Self Drilling Metal	ST 6.3 (No 14)	14-20	14g	20	6.3mm	6.5mm
Deep Driller	ST 5.5 (No 12)	12-24	12g	24	5.5mm	12.5mm
Deep Driller	ST 6.3 (No 14)	14-24	14g	24	6.3mm	12.5mm

The above Maximum Thicknesses are inclusive of the total base material thickness and all applicable air gaps.



### DRILLING CAPACITIES AND THREAD CHARACTERISTICS VORTEX™ UNIVERSAL SCREWS FOR METAL AND TIMBER

TABLE 3

Screw Type	AS 3566-2002 Size Designation	Size	Screw Gauge	Threads Per Inch TPI	Major Diameter (Nominal)	Drilling Capacity (Maximum)
Vortex™ Stud	ST 4.2 (No 8)	M4.2-18	8g	18	4.2mm	2.0mm
Vortex™ Mini	ST 4.8 (No 10)	10-14	10g	14	4.8mm	1.5mm
Vortex™ Fibre	ST 5.0 (No 11)*	M5-14	11g	14	5.0mm	1.6mm
Vortex™ Stud	ST 5.5 (No 12)	M5.4-16	12g	16	5.4mm	2.0mm
Vortex™ Clad	ST 5.5 (No 12)	M6.2-13	12g	13	5.4mm	2.0mm
Vortex™ FibreGlass	ST 5.5 (No 12)	12-13	12g	13	5.4mm	2.4mm
Vortex™ Clad	ST 6.2 (No 13)*	M6.2-13	13g	13	6.2mm	2.0mm
Vortex™ Roof	ST 6.2 (No 13)*	M6.2-13	13g	13	6.2mm	2.0mm
Vortex™ Corri	ST 6.2 (No 13)*	M6.2-13	13g	13	6.2mm	1.5mm
Vortex™ Battenfix	ST 6.2 (No 13)*	M6.2-13	13g	13	6.2mm	2.0mm
Vortex™ Poly	ST 6.2 (No 13)*	M6.2-13	13g	13	6.2mm	1.5mm
Vortex™ Cyclone	ST 6.2 (No 13)*	M6.2-13	13g	13	6.2mm	2.0mm
Vortex™ Shed	ST 6.2 (No 13)*	M6.5-13	13g	13	6.2mm	6.5mm
Vortex™ Stitch	ST 6.5 (No 15)	M6.5-13	15g	13	6.5mm	2.5mm

The above Maximum Thicknesses are inclusive of the total base material thickness and all applicable air gaps.

\* NB. These screws are not yet included in AS 3566

## SCREW SELECTION - TIMBER

## Type 17 POINT

The prime function of a Type 17 Screw is for fastening into timber.



The Type 17 Point is also capable of piercing steel of thicknesses up to 0.75mm.

The dual functionality of the Type 17 drill point has led to its wide acceptance for fastening steel roofing profiles to timber battens in addition to its prime function, fastening timber to timber.

## UNIVERSAL DRILL POINT

The use of high tensile steel in roofing and cladding applications has developed the need for drill points of greater efficiency than traditional T17 screws. The Universal drill point is capable of penetrating metal up to 2.0mm thick and drilling into softwood and less dense hardwoods.



Due to its versatility the Universal drill point is now the style of choice in all applications requiring pierce fastening of steel to timber.

## SCREW SELECTION FOR TIMBER

When selecting timber screws for a specific application the following selection criteria should be followed;

## 1: HEAD STYLE

Select the Head Style most appropriate for the intended application.

## 2: DRILLING POINT STYLE

Select the appropriate drill point style, best suited for the intended application. Type 17, Universal or Needle Point.

## 3: SHANK STYLE

Select a shank style best suited for the intended application, full thread, part thread, TOP GRIP™ or SHANK PROTECTOR™

4: SCREW LENGTH  $l$  (mm)

To ensure optimum clamping force and maximum holding power the selected screw must have a minimum embedment depth,  $h_s$ , into the timber base material.

## 5: PROTECTIVE COATING

Select a corrosion protection system suitable for the intended environmental conditions.

## 6: MECHANICAL PROPERTIES

Check that the mechanical properties of the selected fastener meet the loading requirements of the intended application.

CALCULATION OF SCREW LENGTH ( $l$ )

In order to achieve optimum withdrawal capacities (Pull Out Loads) minimum embedment depths must be achieved.

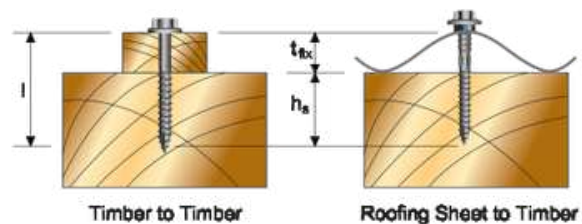
Screw Length  $l$  (mm)

$$l = t_{fix} + h_s$$

Where:

$l$  = Screw Length (mm)

$t_{fix}$  = Thickness of fastened component (mm)

$h_s$  = Required embedment depth (mm)

TABLE 4

Minimum Embedment Depths		
Gauge	$h_s$ (min)	Exceptions
4g	10mm	
6g	16mm	
8g	18mm	
10g	25mm	10gx25 = 23mm
12g	30mm	12gx20 = 18mm 12x25 = 23mm
14g	35mm	14gx25 = 23mm



## FASTENING TIMBER TO METAL WITH WING DRILLING SCREWS

Wing Drilling Screws are specifically designed for fastening timber and composite boards to metal. The special wing feature prevents thread engagement with the timber enabling rapid



fastening without stalling or lifting of the timber before the screw has fully penetrated the base material.

As the drill point drills through the timber the special wings enlarge the hole diameter ensuring that there is clearance between the threads and the timber.

Once the drilling point has fully penetrated the base material the special wings break off on contact with the base material.

The threads on the screw shank then engage and cut mating threads into the base material. The fastener head is then recessed into the fastened material as the required clamping forces are generated.

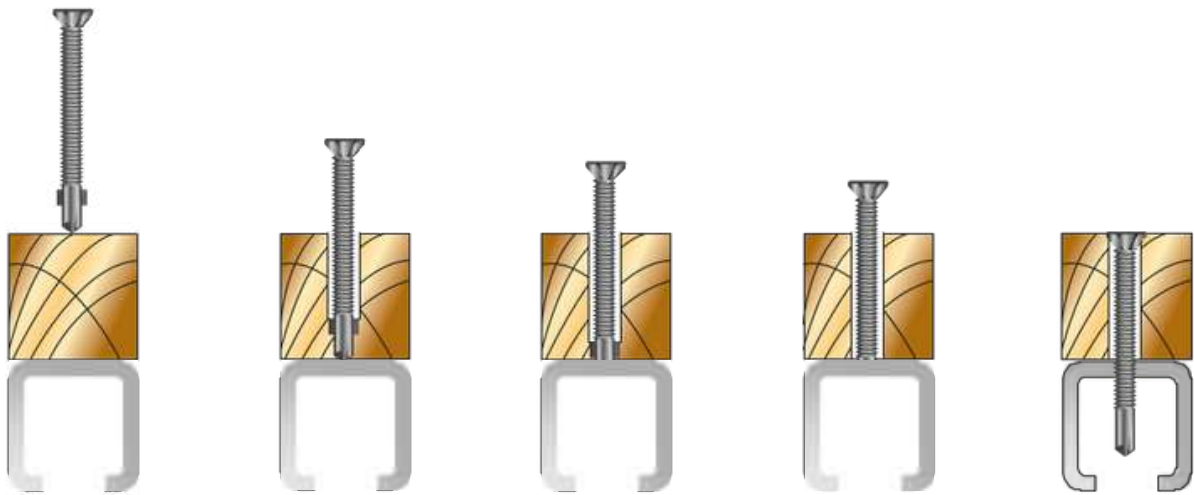

### DRILLING CAPACITIES AND INSTALLATION GUIDE

#### WING DRILLING SCREWS

TABLE 5

Screw Type	Maximum Timber	Minimum Thickness	Maximum Metal Thickness	Power Rating	Power Screw Drive Speed
6g-16x50	37mm	1.0mm	2.4mm		
10g-16x35	20mm	1.2mm	4.5mm		
10g-16x45	27mm	1.2mm	4.5mm		
10-16x50	32mm	1.2mm	4.5mm		
10g-16x55	37mm	1.2mm	4.5mm	380 Watts	2000
10g-16x70	52mm	1.2mm	4.5mm	to 650 Watts	RPM
10g-16x75	57mm	1.2mm	4.5mm		(Minimum)
14g-20x50	32mm	1.9mm	6.5mm		
14g-20x60	42mm	1.9mm	6.5mm		
14g-20x65	47mm	1.9mm	6.5mm		

Caution: For fastening Treated Pine with moisture content exceeding 10% use 12g screws minimum.



## FASTENING ROOF SHEETING TO STEEL WITH METAL DRILLING SCREWS



Bremick manufactures a wide range of roofing screws that are specifically designed for crest fastening roofing profiles to steel supports, purlins and metal battens.

### Single Step Fastening

Each roofing screw is designed to provide a "Single Step" fastening solution. In a single operation Bremick roofing screws pierce metal sheeting, drill into the metal base materials, tap and clamp resulting in a high quality fastening every time.

### PRODUCT FEATURES

- One Step Fastening
- Watertight Seal
- Self Drilling
- TopGrip™ retains sealing pressure
- Shank Protector™ prevents shank corrosion
- Coatings: Class 3, Class 4 or Stainless Steel
- Conforms to Australian Standard AS 3566
- Warrantied performance

### INSTALLATION RECOMMENDATIONS

For best results use a power screw driver with a variable speed from 1000 to 1500 RPM. For thick steel 2000 to 2500 RPM. Battery screw drivers may be used, however due to the low power outputs (torque and RPM) installation time will be significantly increased. Only use Bremick Drive Bits and Sockets.

### SETTING INSTRUCTIONS

#### 1: Position

Insert screw head into drive socket and position screw point at centre of sheet rib.

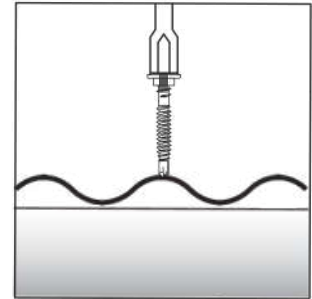

#### 2: Drill

Set the power screw driver to high speed, apply firm pressure to create a start and drive screw whilst maintaining a steady pressure.

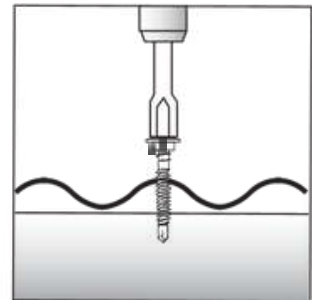

#### 3: Set

Drive screw until the sealing washer is partially compressed. Do not over drive.

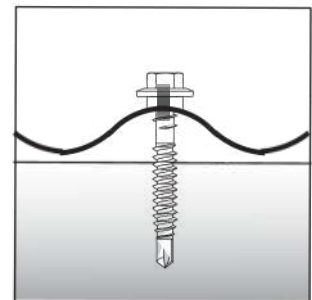

### Seal compression setting

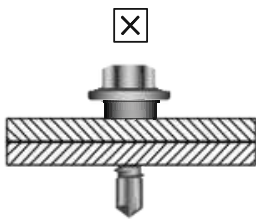

Under driven. Requires tightening

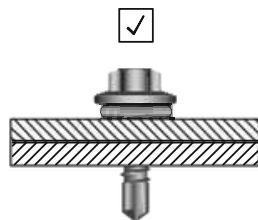

Correct

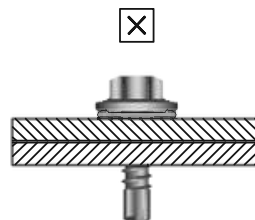

Over driven. Remove and replace.



**CREST  
FIXING**



**VALLEY  
FIXING**

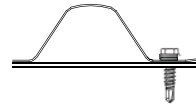

Metal Batten & Timber Thin

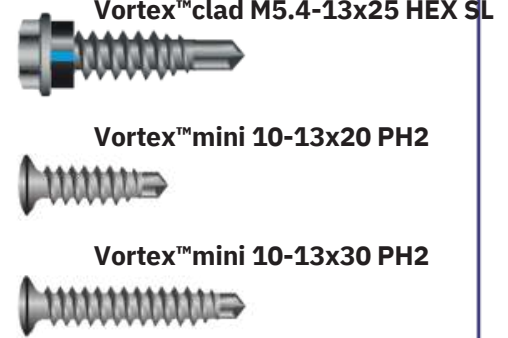
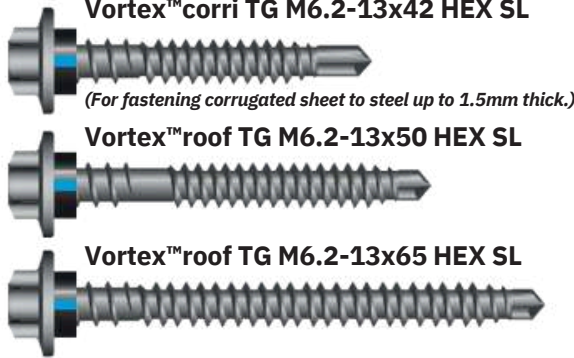

Steel Framing 1.5mm to

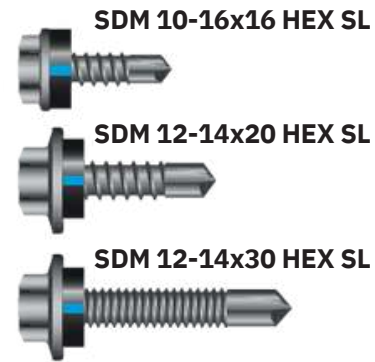
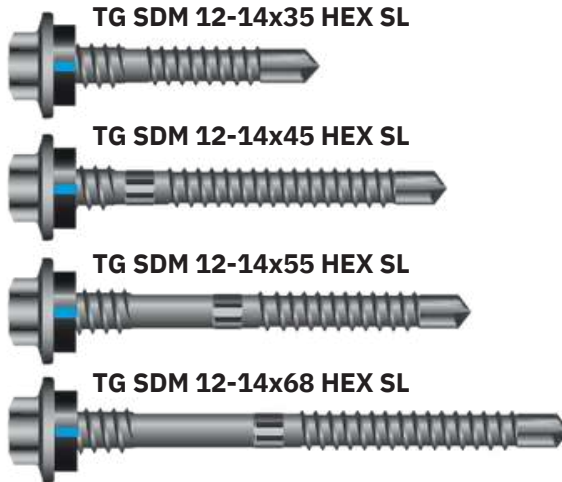

Timber Battens & Fasteners to Hardwood

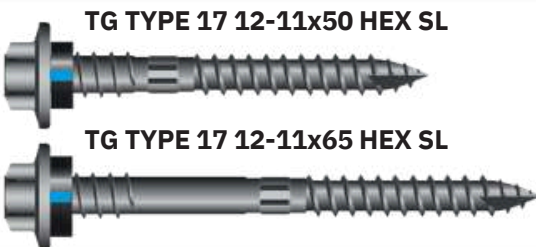

**SECRET CLIP  
FIXING**



**LAP  
STITCHING**



Steel Purlins

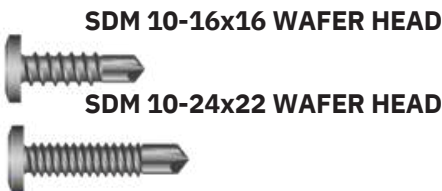

Lap Stitching up to



**METAL BATTEN FIXING**

Fastening timber







## FASTENING ROOF SHEETING TO TIMBER WITH TYPE 17 SCREWS



Bremick manufactures a wide range of Type 17 Self Drilling Screws that are suitable for fastening timber to timber, boards to timber, or thin metal sheeting (0.75mm Max) to timber.

### Single Step Fastening

Each Type 17 screw is designed to provide "Single Step" fastening solution. In a single operation Bremick Type 17 Screws pierce metal sheeting, drill into timber base materials, tap and clamp resulting in a high quality fastening every time.

### PRODUCT FEATURES

- One Step Fastening
- Watertight Seal
- Self Drilling
- TopGrip™ retains sealing pressure
- Shank Protector™ prevents shank corrosion
- Coatings: Class 3, Class 4 or Stainless Steel
- Conforms to Australian Standard AS 3566
- Warrantied performance

### INSTALLATION RECOMMENDATIONS

For best results use a power screw driver with a variable speed from 500 to 1500 RPM.

Battery screw drivers may be used, however due to the low power outputs (torque and RPM) installation time will be significantly increased.

Only use Bremick Drive Bits and Sockets.

Maximum drilling capacity in steel 0.75mm.

### Seal compression setting

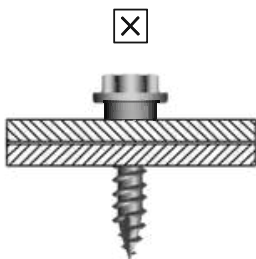

Under driven. Requires tightening

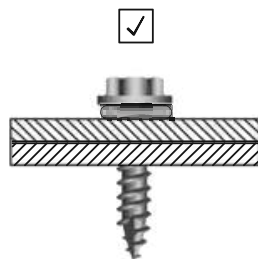

Correct

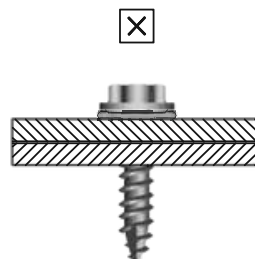

Over driven. Remove and replace.

### SETTING INSTRUCTIONS

#### 1: Position

Insert screw head into drive socket and position screw point at centre of sheet rib. Apply downward pressure so that screw tip creates a start point.

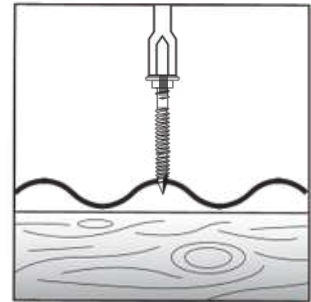

#### 2: Drill

Set the power screw driver to high speed, apply firm pressure to pierce sheeting. Reduce drill speed and drive screw into timber whilst maintaining a steady downward pressure

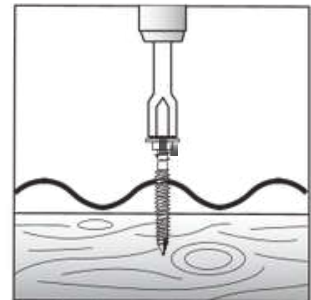

#### 3: Set

Drive screw until the sealing washer is partially compressed. Do not over drive.

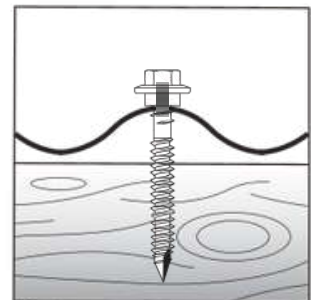



**CREST  
FIXING**



**VALLEY  
FIXING**

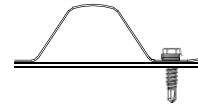

	<p>Vortex™corri TG M6.2-13x42 HEX SL <i>(For fastening corrugated sheet to steel up to 1.5mm thick.)</i></p> <p>Vortex™roof TG M6.2-13x50 HEX SL</p> <p>Vortex™roof TG M6.2-13x65 HEX SL</p>	<p>Vortex™clad M6.2-13x25 HEX SL</p>
<p style="writing-mode: vertical-rl; transform: rotate(180deg);">Steel frame forming to Dense Hardwood up to 2mm thick Timber Battens &amp; Metal Battens &amp; Profiles</p>	<p>SDM 14-10x42 HEX SL</p> <p>SDM 14-10x50 HEX SL</p> <p>SDM 14-10x65 HEX SL</p>	<p>SDM 14-20x22 HEX SL</p> <p>SDM 14-10x25 HEX SL</p>
<p style="writing-mode: vertical-rl; transform: rotate(180deg);">Dense Hardwood up to 2mm thick Timber Battens &amp; Metal Battens &amp; Profiles</p>	<p>TYPE 17 14-10x50 HEX SL</p> <p>TYPE 17 14-10x65 HEX SL</p>	<p>TYPE 17 14-10x25 HEX SL</p> <p>TYPE 17 14-10x40 HEX SL</p>

**SECRET CLIP  
FIXING**



**LAP  
STITCHING**

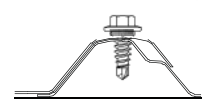

<p style="writing-mode: vertical-rl; transform: rotate(180deg);">Steel to think</p>	<p>SDM 10-16x16 WAFER HEAD</p> <p>SDM 10-24x22 WAFER HEAD</p>	<p style="writing-mode: vertical-rl; transform: rotate(180deg);">Lap stitching up to</p> <p>Vortex™stitch M6.5-13x20 HEX SL</p>
<p style="writing-mode: vertical-rl; transform: rotate(180deg);">Fastening timber</p>	<p>Vortex™battenfi x 12-11x40 HEX</p>	

**METAL BATTEN FIXING**



## ROOFING FASTENERS IN CYCLONIC AREAS

In May 2006 the Building Code of Australia (BCA) was revised to include new performance requirements for all metal roofing systems used in cyclonic areas, Regions C “Tropical Cyclone areas” and Region D “Severe Tropical Cyclone Areas”.

In all Cyclonic Areas it is now a mandatory requirement of the Building Codes of Australia that all metal roofing systems are tested and certified in accordance with BCA 2006 – Volume 1 – Specification B 1.2 “Design of Buildings in Cyclonic Areas”. As such roofing systems, including fasteners must be tested, and must demonstrate adequate fatigue performance, to the new, “Low-High-Low” (LHL) cyclic test method.

We are pleased to advise that all Bremick Cyclone Assemblies have been “Low-High-Low” tested and are performance certified to BCA 2006 – Volume 1 – Specification B 1.2, AS 4040 and AS 1562.1.

## vortex<sup>™</sup> cyclone

The Bremick Vortex™ Cyclone is a preassembled Universal Cyclone Assembly complete with a marine grade Aluminium/EPDM “BRA” Cyclone washer, suitable for use with all corrugated and square rib roofing profiles which is mounted on the Vortex™ self drilling screw, designed for universal application into Timber, Metal Battens and Steel purlins up to 2mm thick.

### The first truly Universal Cyclone Assembly.

#### ArmourCoat™4

- Corrosion protection
- To AS 3566.2

#### Heavy Duty BRA Washer

- Marine Grade Aluminium
- EPDM Extruded Seal
- Non conductive
- 4 Sealing points

#### TopGrip™

- Maintains sealing pressure

#### Vortex™ Thread

- For optimum performance in timber and steel.

#### Universal Drill Point

- Timber, metal battens, Steel purlins

#### Tested & Certified to:

- BCA – Spec B 1.2
- AS 4040
- AS 1562.1
- NT Deemed To Comply



## WIND SPEED

### AS / NZS 1170 Refers Wind Regions - Australia

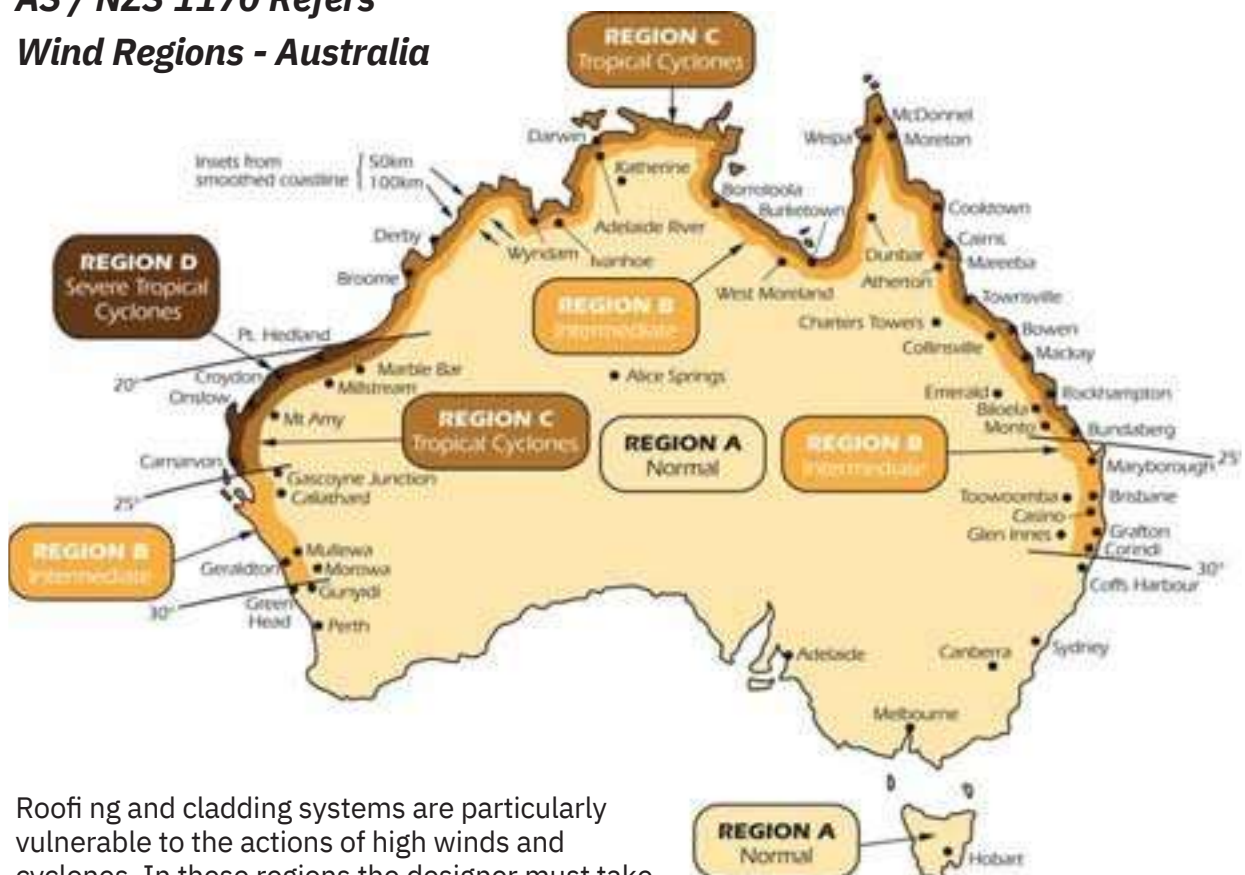

Roofing and cladding systems are particularly vulnerable to the actions of high winds and cyclones. In these regions the designer must take special care to accommodate the additional loading imparted by extreme environmental conditions.

The diagrams opposite identify regions by wind speed category.

In all high wind regions Bremick recommends the use of BRA assemblies that have proven performance under the most arduous test conditions.

For more information regarding wind loading refer to AS/NZS 1170. Or for more information regarding the use of cyclonic and load spreading assemblies contact you local Bremick Service Centre.

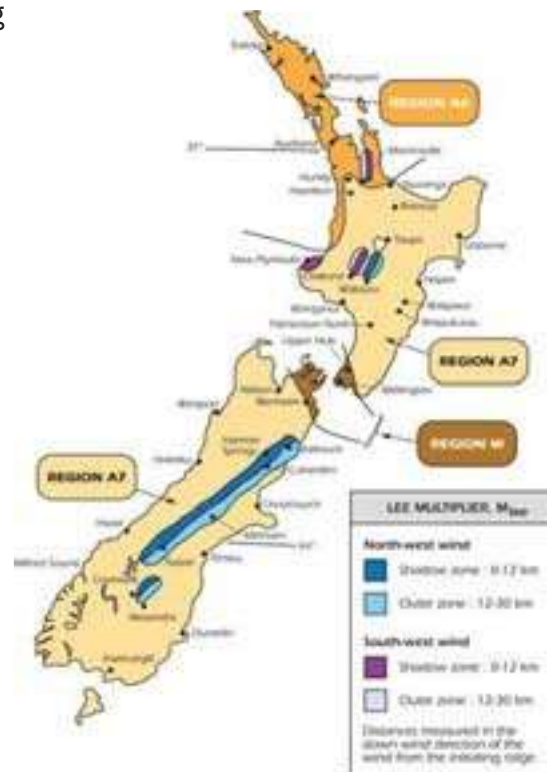

### Wind Regions - New Zealand





## FASTENING ROOF SHEETING IN HIGH WIND & CYCLONIC REGIONS WITH BREMICK ROOFING ASSEMBLIES (BRA)



Bremick Roofing Assemblies (BRA) are preassembled fasteners that are tested and approved for crest fastening metal roofing profiles in Cyclonic Regions. The unique BRA Cyclone washer is suitable for use with most common roofing profiles and is available with universal screws, metal drilling screws or Type 17 timber drilling screws.

Vortex™ Cyclone, Type 17 and Metal drilling versions readily available.

Suitable for Corrugated, Square Rib & Broad Sheet roofing profiles.

### PRODUCT FEATURES

- One Step Fastening
- Suits most profiles
- Watertight Seal
- Universal, Metal Drill or T17
- TopGrip™ retains sealing pressure
- Marine Grade Aluminium/EPDM plate washer
- Coatings: Class 4
- Building Code Australia Tested & Approved
- Conforms to Australian Standard AS 3566
- Warrantied performance

### INSTALLATION RECOMMENDATIONS

For best results use a power screw driver with a variable speed:

For timber 1000 to 1500 RPM.

For steel 2000 to 2500 RPM

Battery screw drivers may be used, however due to the low power outputs (torque and RPM) installation time will be significantly increased.

Only use Bremick Drive Bits and Sockets

### Seal compression setting

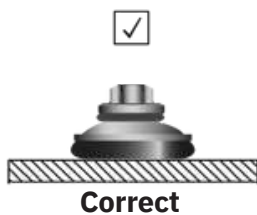

### SETTING INSTRUCTIONS

#### 1: Position

Fit screw head into drive socket and locate screw point at centre of sheet rib. (BRA Cyclone washer can accommodate up to 11 degrees of axial misalignment)

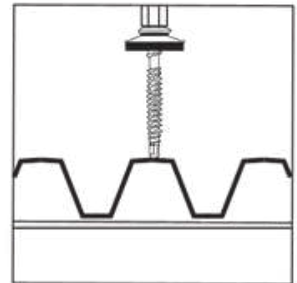

#### 2: Drill

With a power screw driver commence drilling at “slow speed” to pierce sheeting.

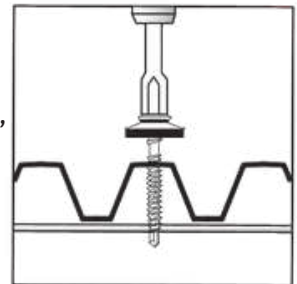

#### 3: Set

Maintaining a firm down pressure increase the drive speed to penetrate the base material. Continue driving until the BRA Washer seats firmly.

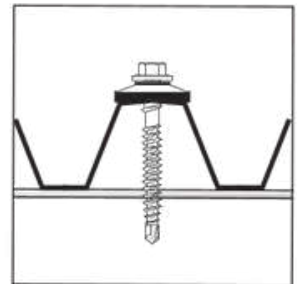

**CREST  
FIXING**



**VALLEY  
FIXING**

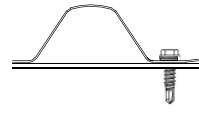

Timber Battens, Thin Metal Battens & Purlins up to 15mm thick



Steel Purlins up to 15mm thick

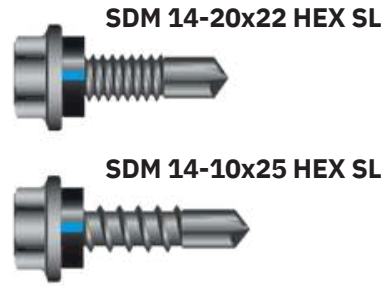
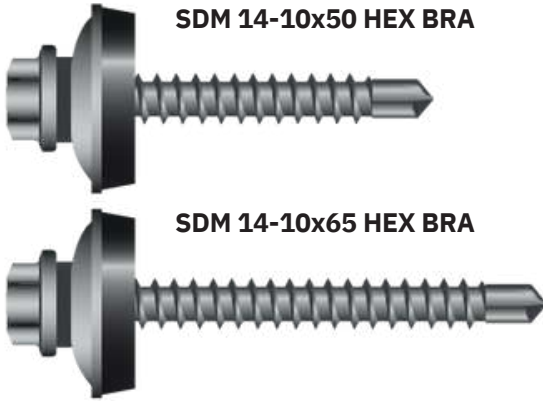

Up Fastening to Timber Battens & Dense Hardwood

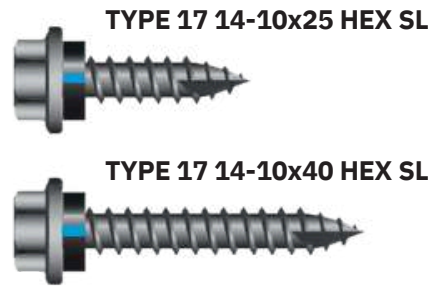
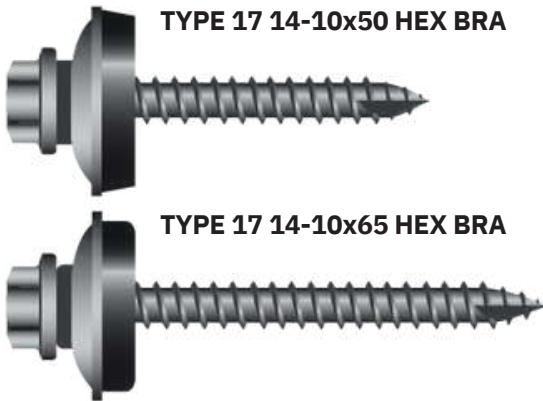

Lap Stitching up to 1.5mm thick

**LAP  
STITCHING**





TEST AND CERTIFICATION - REGISTER

In accordance with Building Codes of Australia all Bremick Cyclone Assemblies have been independently performance tested in conjunction with all common metal roofing systems using the “Low-High-Low” test methodology and as such have been performance certified to BCA 2006 – Volume 1 – Specification B 1.2, AS 4040 and AS 1562.1.

The current listing of Tests and Certification numbers are given below:

**BREMICK ROOFING ASSEMBLIES - (BRA)  
LOW-Hi LOW TESTING AND CERTIFICATION**

**Building Codes of Australia Specification B 1.2, AS 1562.1 & AS 4040  
WITH CYCLONE PLATE - BRA**



TABLE 6

DATE	TEST AUTHORITY	CERTIFICATION BODY	PROJECT NUMBER	CERTIFICATE NUMBER	FASTENER	FASTENING MODE	PROFILE	BASE MATERIAL	COMMENTS
Mar-09	University of Adelaide	Trevor John & Associates	41666	TR01		Crest Fix	Corrugated 0.42mm G550	Steel 1.5mm BMT - G450	PASSED: AS 1562.1, AS 4040, BCA Specification B1.2
Mar-09	University of Adelaide	Trevor John & Associates	41666	TR03	Vortex™ Cyclone	Crest Fix	Corrugated 0.42mm G550	Steel 0.75mm BMT - G550	PASSED: AS 1562.1, AS 4040, BCA Specification B1.2
Mar-09	University of Adelaide	Trevor John & Associates	41666	TR05	Vortex™ Cyclone	Crest Fix	Corrugated 0.42mm G550	MT4 Hardwood	PASSED: AS 1562.1, AS 4040, BCA Specification B1.2
Mar-09	University of Adelaide	Trevor John & Associates	41666	TR07	Vortex™ Cyclone	Crest Fix	Square Rib 0.42mm BMT G550	Steel 1.5mm BMT - G450	PASSED: AS 1562.1, AS 4040, BCA Specification B1.2
Mar-09	University of Adelaide	Trevor John & Associates	41666	TR09	Vortex™ Cyclone	Crest Fix	Square Rib Broad Sheet 0.42mm BMT G550	Steel 0.75mm BMT - G550	PASSED: AS 1562.1, AS 4040, BCA Specification B1.2
Mar-09	BlueScope Lysaght Technology	BlueScope Lysaght Technology	41666	TR11	Vortex™ Cyclone	Crest Fix	Square Rib 0.48mm BMT G550	Steel 1.5mm BMT - G450	PASSED: AS 1562.1, AS 4040, BCA Specification B1.2
Mar-09	University of Adelaide	Trevor John & Associates	N/A	11/03/09/1	Vortex™ Cyclone	Crest Fix	Corrugated 0.42mm G550	Steel 0.75mm BMT - G550	PASSED: AS 1562.1, AS 4040, BCA Specification B1.2
Mar-09	University of Adelaide	Trevor John & Associates	41666	TR04	TYPE 17 14g-10 BRA Assembly	Crest Fix	Corrugated 0.42mm G550	MT4 Hardwood	PASSED: AS 1562.1, AS 4040, BCA Specification B1.2
Mar-09	University of Adelaide	Trevor John & Associates	41666	TR06	TYPE 17 14g-10 BRA Assembly	Crest Fix	Square Rib 0.42mm BMT G550	Corrugated 0.42mm BMT	PASSED: AS 1562.1, AS 4040, BCA Specification B1.2
Mar-09	University of Adelaide	Trevor John & Associates	41666	TR10	BRA Assembly SDM 14g-10 BRA	Crest Fix	G550	Steel 0.75mm BMT - G550	PASSED: AS 1562.1, AS 4040, BCA Specification B1.2
Mar-09	University of Adelaide	Trevor John & Associates	41666	TR02	SDM 14g-10 BRA Assembly	Crest Fix	Square Rib Broad Sheet 0.42mm BMT G550	Steel 1.5mm BMT - G450	PASSED: AS 1562.1, AS 4040, BCA Specification B1.2
Apr-09	BlueScope Lysaght Technology	BlueScope Lysaght Technology	41666	TR08	SDM 14g-10 BRA Assembly	Crest Fix	Square Rib Broad Sheet 0.42mm BMT G550	Steel 1.5mm BMT - G450	PASSED: AS 1562.1, AS 4040, BCA Specification B1.2
Apr-09	University of Adelaide	James Cook	41666	TR12	SDM 14g-10 BRA Assembly	Crest Fix	Square Rib Broad Sheet 0.42mm BMT G550	Steel 1.9mm BMT - G450	PASSED: AS 1562.1, AS 4040, BCA Specification B1.2
Mar-09	University of Adelaide		N/A	11/03/09/1	Vortex™ Cyclone	Crest Fix		Pan Steel 0.75mm BMT - G450	PASSED: AS 1562.1, AS 4040, BCA Specification B1.2
Aug-07			TS666	TS666a		Pan Fix	0.35mm BMT G550	G550	PASSED: AS 1562.1, AS 4040, BCA Specification B1.2
Aug-07		Cyclone Testing Station	TS666	TS666b	Vortex™ Cyclone	Crest Fix	Square Rib Broad Sheet 0.42mm BMT G550	Pan Steel 0.75mm BMT - G450	PASSED: AS 1562.1, AS 4040, BCA Specification B1.2

**BREMICK ROOFING ASSEMBLIES  
LOW-Hi LOW TESTING AND CERTIFICATION**

**Building Codes of Australia Specification B 1.2, AS 1562.1 & AS 4040  
WITH CYCLONE PLATE & SEAL - CST**



TABLE 7

DATE	TEST AUTHORITY	CERTIFICATION BODY	PROJECT NUMBER	CERTIFICATE NUMBER	FASTENER	FASTENING MODE	PROFILE	BASE MATERIAL	COMMENTS
Mar-09	BlueScope Lysaght Technology	BlueScope Lysaght Technology	N/A	11/03/09/1	SDM 14-10 C/Orb Plate Assembly	Crest Fix	Custom Orb Corrugated 0.42mm BMT G550	Steel 1.9mm BMT - G450	PASSED: AS 1562.1, AS 4040, BCA Specification B1.2



**BREMICK ROOFING ASSEMBLIES (PLATE ASSEMBLIES)  
LOW-Hi LOW TESTING AND CERTIFICATION**

**Building Codes of Australia Specification B 1.2, AS 1562.1 & AS 4040  
WITH CYCLONE PLATE & SEAL - TRM**

**TABLE 8**



DATE	TEST AUTHORITY	CERTIFICATION BODY	PROJECT NUMBER	CERTIFICATE NUMBER	FASTENER	FASTENING MODE	PROFILE	BASE MATERIAL	COMMENTS
Mar-09	BlueScope Lysaght Technology	BlueScope Lysaght Technology	N/A	11/03/09/1	SDM 14-10 TRM/ SPAN Plate Assembly	Crest Fix	Trimdek 0.42mm G550	BMT Steel 1.9mm - G450	PASSED: AS 1562.1, AS 4040, BCA Specification B1.2
Jul-07	University of Adelaide	Trevor John & Associates	37308.3	HR 680 900	SDM 14-10 TRM/ SPAN Plate Assembly	Crest Fix	Hi-Rib 680 0.42mm BMT G550	Steel 1.5mm BMT - G450	PASSED: AS 1562.1, AS 4040, BCA Specification B1.2
Jul-07	University of Adelaide	Trevor John & Associates	37308.3	HR 680 1200	SDM 14-10 TRM/ SPAN Plate Assembly	Crest Fix	Hi-Rib 680 0.42mm BMT G550	Steel 1.5mm BMT - G450	PASSED: AS 1562.1, AS 4040, BCA Specification B1.2
Jul-07	University of Adelaide	Trevor John & Associates	37308.3	HR 680 1500	SDM 14-10 TRM/ SPAN Plate Assembly	Crest Fix	Hi-Rib 680 0.42mm BMT G550	Steel 1.5mm BMT - G450	PASSED: AS 1562.1, AS 4040, BCA Specification B1.2
Jul-07	University of Adelaide	Trevor John & Associates	37308.3	HR 680 1800	SDM 14-10 TRM/ SPAN Plate Assembly	Crest Fix	Hi-Rib 680 0.42mm BMT G550	Steel 1.5mm BMT - G450	PASSED: AS 1562.1, AS 4040, BCA Specification B1.2
Aug-07	University of Adelaide	Associates	37308	HR 680.42 900x900	SDM 14-10 TRM/ SPAN Plate Assembly	Crest Fix	Hi-Rib 680 0.42mm BMT G550	Steel 1.5mm BMT - G450	PASSED: AS 1562.1, AS 4040, BCA Specification B1.2
Aug-07	University of Adelaide	Associates	37308	HR 680.42 1200x1200	SDM 14-10 TRM/ SPAN Plate Assembly	Crest Fix	Hi-Rib 680 0.42mm BMT G550	Steel 1.5mm BMT - G450	PASSED: AS 1562.1, AS 4040, BCA Specification B1.2
Aug-07	University of Adelaide	Associates	37308	HR 680.42 1500x1500	SDM 14-10 TRM/ SPAN Plate Assembly	Crest Fix	Hi-Rib 680 0.42mm BMT G550	Steel 1.5mm BMT - G450	PASSED: AS 1562.1, AS 4040, BCA Specification B1.2
Aug-07	University of Adelaide	Associates	37308	HR 680.42 1800x1800	SDM 14-10 TRM/ SPAN Plate Assembly	Crest Fix	Hi-Rib 680 0.42mm BMT G550	Steel 1.5mm BMT - G450	PASSED: AS 1562.1, AS 4040, BCA Specification B1.2
Aug-07	University of Adelaide	Associates	37308	HR 680.42 900 1150	SDM 14-10 TRM/ SPAN Plate Assembly	Crest Fix	Hi-Rib 680 0.42mm BMT G550	Steel 1.5mm BMT - G450	PASSED: AS 1562.1, AS 4040, BCA Specification B1.2
Aug-07	University of Adelaide	Associates	37308	HR 680.42 1200 1500	SDM 14-10 TRM/ SPAN Plate Assembly	Crest Fix	Hi-Rib 680 0.42mm BMT G550	Steel 1.5mm BMT - G450	PASSED: AS 1562.1, AS 4040, BCA Specification B1.2
Aug-07	University of Adelaide	Associates	37308	HR 680.42 1400 1750	SDM 14-10 TRM/ SPAN Plate Assembly	Crest Fix	Hi-Rib 680 0.42mm BMT G550	Steel 1.5mm BMT - G450	PASSED: AS 1562.1, AS 4040, BCA Specification B1.2
Aug-07	University of Adelaide	Associates	37308	HR 680.42 1600 2000	SDM 14-10 TRM/ SPAN Plate Assembly	Crest Fix	Hi-Rib 680 0.42mm BMT G550	Steel 1.5mm BMT - G450	PASSED: AS 1562.1, AS 4040, BCA Specification B1.2
Aug-07	University of Adelaide	Associates	37308	HR 680.48 1200	SDM 14-10 TRM/ SPAN Plate Assembly	Crest Fix	Hi-Rib 680 0.48mm BMT G550	Steel 1.5mm BMT - G450	PASSED: AS 1562.1, AS 4040, BCA Specification B1.2
Jul-07	University of Adelaide	Associates	37038.3		SDM 14-10 TRM/ SPAN Plate Assembly	Crest Fix	Hi-Rib 680 0.48mm BMT G550	Steel 1.5mm BMT - G450	PASSED: AS 1562.1, AS 4040, BCA Specification B1.2
Jul-07	University of Adelaide	Associates	37038.3	HR 680.48 1500	SDM 14-10 TRM/ SPAN Plate Assembly	Crest Fix	Hi-Rib 680 0.48mm BMT G550	Steel 1.5mm BMT - G450	PASSED: AS 1562.1, AS 4040, BCA Specification B1.2
Jul-07	University of Adelaide	Associates	37038.3	HR 680.48 1800	SDM 14-10 TRM/ SPAN Plate Assembly	Crest Fix	Hi-Rib 680 0.48mm BMT G550	Steel 1.5mm BMT - G450	PASSED: AS 1562.1, AS 4040, BCA Specification B1.2
Jul-07	University of Adelaide	Associates	37038.3	HR 680.48 2100	SDM 14-10 TRM/ SPAN Plate Assembly	Crest Fix	Hi-Rib 680 0.48mm BMT G550	Steel 1.5mm BMT - G450	PASSED: AS 1562.1, AS 4040, BCA Specification B1.2
Aug-07	University of Adelaide	Associates	37308	HR 680.48 1200x1200	SDM 14-10 TRM/ SPAN Plate Assembly	Crest Fix	Hi-Rib 680 0.48mm BMT G550	Steel 1.5mm BMT - G450	PASSED: AS 1562.1, AS 4040, BCA Specification B1.2
Aug-07	University of Adelaide	Associates	37308	HR 680.48 1500x1500	SDM 14-10 TRM/ SPAN Plate Assembly	Crest Fix	Hi-Rib 680 0.48mm BMT G550	Steel 1.5mm BMT - G450	PASSED: AS 1562.1, AS 4040, BCA Specification B1.2
Aug-07	University of Adelaide	Associates	37308	HR 680.48 1800x1800	SDM 14-10 TRM/ SPAN Plate Assembly	Crest Fix	Hi-Rib 680 0.48mm BMT G550	Steel 1.5mm BMT - G450	PASSED: AS 1562.1, AS 4040, BCA Specification B1.2
Aug-07	University of Adelaide	Associates	37308	HR 680.48 2100x2100	SDM 14-10 TRM/ SPAN Plate Assembly	Crest Fix	Hi-Rib 680 0.48mm BMT G550	Steel 1.5mm BMT - G450	PASSED: AS 1562.1, AS 4040, BCA Specification B1.2
Aug-07	University of Adelaide	Associates	37308	HR 680.48 900 1150	SDM 14-10 TRM/ SPAN Plate Assembly	Crest Fix	Hi-Rib 680 0.48mm BMT G550	Steel 1.5mm BMT - G450	PASSED: AS 1562.1, AS 4040, BCA Specification B1.2
Aug-07	University of Adelaide	Associates	37308	HR 680.48 1200 1500	SDM 14-10 TRM/ SPAN Plate Assembly	Crest Fix	Hi-Rib 680 0.48mm BMT G550	Steel 1.5mm BMT - G450	PASSED: AS 1562.1, AS 4040, BCA Specification B1.2
Aug-07	University of Adelaide	Associates	37308	HR 680.48 1400 1750	SDM 14-10 TRM/ SPAN Plate Assembly	Crest Fix	Hi-Rib 680 0.48mm BMT G550	Steel 1.5mm BMT - G450	PASSED: AS 1562.1, AS 4040, BCA Specification B1.2
Aug-07	University of Adelaide	Associates	37308	HR 680.48 1600 2000	SDM 14-10 TRM/ SPAN Plate Assembly	Crest Fix	Hi-Rib 680 0.48mm BMT G550	Steel 1.5mm BMT - G450	PASSED: AS 1562.1, AS 4040, BCA Specification B1.2
Aug-07	University of Adelaide	Associates	37308	HR 680.6. 900	SDM 14-10 TRM/ SPAN Plate Assembly	Crest Fix	Hi-Rib 680 0.60mm BMT G300	Steel 1.5mm BMT - G450	PASSED: AS 1562.1, AS 4040, BCA Specification B1.2
Jul-07	University of Adelaide	Associates	37038.3		SDM 14-10 TRM/ SPAN Plate Assembly	Crest Fix	Hi-Rib 680 0.60mm BMT G300	Steel 1.5mm BMT - G450	PASSED: AS 1562.1, AS 4040, BCA Specification B1.2
Jul-07	University of Adelaide	Associates	37038.3	HR 680.6. 1200	SDM 14-10 TRM/ SPAN Plate Assembly	Crest Fix	Hi-Rib 680 0.60mm BMT G300	Steel 1.5mm BMT - G450	PASSED: AS 1562.1, AS 4040, BCA Specification B1.2
Jul-07	University of Adelaide	Associates	37038.3	HR 680.6. 1500	SDM 14-10 TRM/ SPAN Plate Assembly	Crest Fix	Hi-Rib 680 0.60mm BMT G300	Steel 1.5mm BMT - G450	PASSED: AS 1562.1, AS 4040, BCA Specification B1.2
Jul-07	University of Adelaide	Associates	37038.3	HR 680.6. 1800	SDM 14-10 TRM/ SPAN Plate Assembly	Crest Fix	Hi-Rib 680 0.60mm BMT G300	Steel 1.5mm BMT - G450	PASSED: AS 1562.1, AS 4040, BCA Specification B1.2
Aug-07	University of Adelaide	Associates	37308	HR 680.55 900x900	SDM 14-10 TRM/ SPAN Plate Assembly	Crest Fix			PASSED: AS 1562.1, AS 4040, BCA Specification B1.2

CONTINUED OVER PAGE >>

Custom Orb® and TrimDek are registered trademarks of BlueScope Lysaght®

Hi-Rib® is a registered trademark of Fielders Ltd



<< CONTIUNUED FROM PREVIOUS PAGE

DATE	TEST AUTHORITY	CERTIFICATION BODY	PROJECT NUMBER	CERTIFICATE NUMBER	FASTENER	FASTENING MODE	PROFILE	BASE MATERIAL	COMMENTS
Aug-07	University of Adelaide	Trevor John & Associates	37308	HR 680.55 1200x1200	SDM 14-10 TRM/SPAN Plate Assembly	Crest Fix	Hi-Rib 680 0.55mm BMT G300	Steel 1.5mm BM - G450	PASSED: AS 1562.1, AS 4040, BCA Specifi cation B1.2
Aug-07	University of Adelaide	Trevor John & Associates	37308	HR 680.55 1500x1500	SDM 14-10 TRM/SPAN Plate Assembly	Crest Fix	Hi-Rib 680 0.55mm BMT G300	Steel 1.5mm BM - G450	PASSED: AS 1562.1, AS 4040, BCA Specifi cation B1.2
Aug-07	University of Adelaide	Trevor John & Associates	37308	HR 680.55 1800x1800	SDM 14-10 TRM/SPAN Plate Assembly	Crest Fix	Hi-Rib 680 0.55mm BMT G300	Steel 1.5mm BM - G450	PASSED: AS 1562.1, AS 4040, BCA Specifi cation B1.2
Aug-07	University of Adelaide	Trevor John & Associates	37308	HR 680.55 900 1150 900	SDM 14-10 TRM/SPAN Plate Assembly	Crest Fix	Hi-Rib 680 0.55mm BMT G300	Steel 1.5mm BM - G450	PASSED: AS 1562.1, AS 4040, BCA Specifi cation B1.2
Aug-07	University of Adelaide	Trevor John & Associates	37308	HR 680.55 1200 1500 1200	SDM 14-10 TRM/SPAN Plate Assembly	Crest Fix	Hi-Rib 680 0.55mm BMT G300	Steel 1.5mm BM - G450	PASSED: AS 1562.1, AS 4040, BCA Specifi cation B1.2
Aug-07	University of Adelaide	Trevor John & Associates	37308	HR 680.55 1400 1750 1400	SDM 14-10 TRM/SPAN Plate Assembly	Crest Fix	Hi-Rib 680 0.55mm BMT G300	Steel 1.5mm BM - G450	PASSED: AS 1562.1, AS 4040, BCA Specifi cation B1.2
Aug-07	University of Adelaide	Trevor John & Associates	37308	HR 680.55 1600 2000 1600	SDM 14-10 TRM/SPAN Plate Assembly	Crest Fix	Hi-Rib 680 0.55mm BMT G300	Steel 1.5mm BM - G450	PASSED: AS 1562.1, AS 4040, BCA Specifi cation B1.2

**BREMICK ROOFING ASSEMBLIES (PLATE ASSEMBLIES) LOW-Hi LOW TESTING AND CERTIFICATION**

**Building Codes of Australia Specifi cation B 1.2, AS 1562.1 & AS 4040 WITH CYCLONE PLATE & SEAL - FKK/KLP**



TABLE 9

DATE	TEST AUTHORITY	CERTIFICATION BODY	PROJECT NUMBER	CERTIFICATE NUMBER	FASTENER	FASTENING MODE	PROFILE	BASE MATERIAL	COMMENTS
Sep-07	University of Adelaide	Trevor John & Associates	37308	KK 700 900 Screw fi x	SDM 14-10 King/Klip Plate Assembly	Crest Fix	King Klip 700 .42mm BMT G550	Steel 1.5mm BM - G450	PASSED: AS 1562.1, AS 4040, BCA Specifi cation B1.2
Sep-07	University of Adelaide	Trevor John & Associates	37308	KK 700 1200 Screw fi x	SDM 14-10 King/Klip Plate Assembly	Crest Fix	King Klip 700 .42mm BMT G550	Steel 1.5mm BM - G450	PASSED: AS 1562.1, AS 4040, BCA Specifi cation B1.2
Sep-07	University of Adelaide	Trevor John & Associates	37308	KK 700 1500 Screw fi x	SDM 14-10 King/Klip Plate Assembly	Crest Fix	King Klip 700 .42mm BMT G550	Steel 1.5mm BM - G450	PASSED: AS 1562.1, AS 4040, BCA Specifi cation B1.2
Sep-07	University of Adelaide	Trevor John & Associates	37308	KK 700 1800 Screw fi x	SDM 14-10 King/Klip Plate Assembly	Crest Fix	King Klip 700 .42mm BMT G550	Steel 1.5mm BM - G450	PASSED: AS 1562.1, AS 4040, BCA Specifi cation B1.2
Sep-07	University of Adelaide	Trevor John & Associates	37308	KK 700.42 900x900 Screw fi x	SDM 14-10 King/Klip Plate Assembly	Crest Fix	King Klip 700 .42mm BMT G550	Steel 1.5mm BM - G450	PASSED: AS 1562.1, AS 4040, BCA Specifi cation B1.2
Sep-07	University of Adelaide	Trevor John & Associates	37308	KK 700.42 1200x1200 Screw fi x	SDM 14-10 King/Klip Plate Assembly	Crest Fix	King Klip 700 .42mm BMT G550	Steel 1.5mm BM - G450	PASSED: AS 1562.1, AS 4040, BCA Specifi cation B1.2
Sep-07	University of Adelaide	Trevor John & Associates	37308	KK 700.42 1500x1500 Screw fi x	SDM 14-10 King/Klip Plate Assembly	Crest Fix	King Klip 700 .42mm BMT G550	Steel 1.5mm BM - G450	PASSED: AS 1562.1, AS 4040, BCA Specifi cation B1.2
Sep-07	University of Adelaide	Trevor John & Associates	37308	KK 700.42 1800x1800 Screw fi x	SDM 14-10 King/Klip Plate Assembly	Crest Fix	King Klip 700 .42mm BMT G550	Steel 1.5mm BM - G450	PASSED: AS 1562.1, AS 4040, BCA Specifi cation B1.2
Sep-07	University of Adelaide	Trevor John & Associates	37308	KK 700.42 900 1150 900 Screw fi x	SDM 14-10 King/Klip Plate Assembly	Crest Fix	King Klip 700 .42mm BMT G550	Steel 1.5mm BM - G450	PASSED: AS 1562.1, AS 4040, BCA Specifi cation B1.2
Sep-07	University of Adelaide	Trevor John & Associates	37308	KK 700.42 1400 1750 1400 Screw fi x	SDM 14-10 King/Klip Plate Assembly	Crest Fix	King Klip 700 .42mm BMT G550	Steel 1.5mm BM - G450	PASSED: AS 1562.1, AS 4040, BCA Specifi cation B1.2
Sep-07	University of Adelaide	Trevor John & Associates	37308	KK 700.42 1600 2000 1600 Screw fi x	SDM 14-10 King/Klip Plate Assembly	Crest Fix	King Klip 700 .48mm BMT G550	Steel 1.5mm BM - G450	PASSED: AS 1562.1, AS 4040, BCA Specifi cation B1.2
Sep-07	University of Adelaide	Trevor John & Associates	37308	0.48 KK 700 1200 Screw fi x	SDM 14-10 King/Klip Plate Assembly	Crest Fix	King Klip 700 .48mm BMT G550	Steel 1.5mm BM - G450	PASSED: AS 1562.1, AS 4040, BCA Specifi cation B1.2
Sep-07	University of Adelaide	Trevor John & Associates	37308	0.48 KK 700 1500 Screw fi x	SDM 14-10 King/Klip Plate Assembly	Crest Fix	King Klip 700 .48mm BMT G550	Steel 1.5mm BM - G450	PASSED: AS 1562.1, AS 4040, BCA Specifi cation B1.2
Sep-07	University of Adelaide	Trevor John & Associates	37308	0.48 KK 700 1800 Screw fi x	SDM 14-10 King/Klip Plate Assembly	Crest Fix	King Klip 700 .48mm BMT G550	Steel 1.5mm BM - G450	PASSED: AS 1562.1, AS 4040, BCA Specifi cation B1.2
Sep-07	University of Adelaide	Trevor John & Associates	37308	0.48 KK 700 2100 Screw fi x	SDM 14-10 King/Klip Plate Assembly	Crest Fix	King Klip 700 .48mm BMT G550	Steel 1.5mm BM - G450	PASSED: AS 1562.1, AS 4040, BCA Specifi cation B1.2
Sep-07	University of Adelaide	Trevor John & Associates	37308	0.48 KK 700 1200 Screw fi x	SDM 14-10 King/Klip Plate Assembly	Crest Fix	King Klip 700 .48mm BMT G550	Steel 1.5mm BM - G450	PASSED: AS 1562.1, AS 4040, BCA Specifi cation B1.2
Sep-07	University of Adelaide	Trevor John & Associates	37308	1500x1500 Screw fi x	SDM 14-10 King/Klip Plate Assembly	Crest Fix	King Klip 700 .48mm BMT G550	Steel 1.5mm BM - G450	PASSED: AS 1562.1, AS 4040, BCA Specifi cation B1.2
Sep-07	University of Adelaide	Trevor John & Associates	37308	1800x1800 Screw fi x	SDM 14-10 King/Klip Plate Assembly	Crest Fix	King Klip 700 .48mm BMT G550	Steel 1.5mm BM - G450	PASSED: AS 1562.1, AS 4040, BCA Specifi cation B1.2
Sep-07	University of Adelaide	Trevor John & Associates	37308	2100x2100 Screw fi x	SDM 14-10 King/Klip Plate Assembly	Crest Fix	King Klip 700 .48mm BMT G550	Steel 1.5mm BM - G450	PASSED: AS 1562.1, AS 4040, BCA Specifi cation B1.2
Sep-07	University of Adelaide	Trevor John & Associates	37308	0.48 KK 700 900 1150 900 Screw fi x	SDM 14-10 King/Klip Plate Assembly	Crest Fix	King Klip 700 .48mm BMT G550	Steel 1.5mm BM - G450	PASSED: AS 1562.1, AS 4040, BCA Specifi cation B1.2
Sep-07	University of Adelaide	Trevor John & Associates	37308	0.48 KK 700 1200 1500 1200 Screw fi x	SDM 14-10 King/Klip Plate Assembly	Crest Fix	King Klip 700 .48mm BMT G550	Steel 1.5mm BM - G450	PASSED: AS 1562.1, AS 4040, BCA Specifi cation B1.2
Sep-07	University of Adelaide	Trevor John & Associates	37308	0.48 KK 700 1400 1750 1400 Screw fi x	SDM 14-10 King/Klip Plate Assembly	Crest Fix	King Klip 700 .48mm BMT G550	Steel 1.5mm BM - G450	PASSED: AS 1562.1, AS 4040, BCA Specifi cation B1.2
Sep-07	University of Adelaide	Trevor John & Associates	37308	0.48 KK 700 1600 2000 1600 Screw fi x	SDM 14-10 King/Klip Plate Assembly	Crest Fix	King Klip 700 .48mm BMT G550	Steel 1.5mm BM - G450	PASSED: AS 1562.1, AS 4040, BCA Specifi cation B1.2

KingKlip® is a registered trademark of Fielders Ltd  
KlipLok® is a registered trademark of BlueScope Lysaght Ltd.



GENERAL MECHANICAL PROPERTIES

VORTEX™ UNIVERSAL SCREWS  
CHARACTERISTIC CAPACITIES



TABLE 11

Fastener VORTEX™	Single Shear KN	Axial Tensile KN	Torsional Nm
Vortex Stud M4.2	5.8	6.5	5.9
Vortex Stud M5.4	6.3	11.1	8.3
Vortex Mini	6.3	11.1	8.3
Vortex Fibre M5	6.5	11.4	8.6
Vortex Clad M5.4	8.4	14.4	14.5
Vortex Clad M6.2	11.0	16.7	14.1
Vortex Poly	8.4	16.7	14.1
Vortex FibreGlass	11.0	14.4	13.1
Vortex Roof	11.0	16.7	14.1
Vortex Corri	11.0	16.7	14.1
Vortex Cyclone	9.5	16.7	14.1
Vortex Batten Fix	12.3	15.8	13.3
Vortex Shed	8.9	19.3	20.3
Vortex Stitch	19.7	15.9	20.0
Vortex Truss	12.5	33.7	30.0
Vortex Frame	6.9	21.2	17.5
Vortex Deck (SS 316)		11.8	9.1

GENERAL MECHANICAL PROPERTIES

SELF DRILLING FOR METAL SCREWS  
CHARACTERISTIC CAPACITIES



TABLE 12

Fastener r SDM	Single Shear KN	Axial Tensile KN	Torsional Nm
6-18	4.9	6.2	3.6
6-20	4.9	6.1	3.7
8-18	5.8	6.5	5.9
10-16	6.3	11.1	8.3
10-24	6.0	11.2	9.1
12-14	8.4	14.4	13.1
12-24	8.9	16.0	13.3
14-10	11.1	20.3	20.8
14-14	11.4	19.5	21.0
14-20	10.3	19.5	23.8

Please Note: The above data represents characteristic capacities obtained under laboratory conditions and are only applicable to Bremick products. The design professional must apply appropriate safety factors.



## GENERAL MECHANICAL PROPERTIES

## TYPE 17 SCREWS

## CHARACTERISTIC CAPACITIES

TABLE 13



Fastener TYPE 17	Single Shear KN	Axial Tensile KN	Torsional Nm
6-18	4.9	6.2	3.6
8-10	4.6	7.9	5.6
8-15	4.1	8.7	5.9
8-18	6.9	8.6	6.0
10-12	10.1	11.8	7.2
12-11	9.4	15.6	13.3
14-10	11.6	20.3	20.8

## GENERAL MECHANICAL PROPERTIES

## NEEDLE POINT SCREWS

## CHARACTERISTIC CAPACITIES

TABLE 14



Fastener NEEDLE POINT	Single Shear KN	Axial Tensile KN	Torsional Nm
6-9	3.0	5.1	3.4
6-18	3.3	5.5	3.6
7-16	3.4	5.8	4.5
8-10	4.6	7.9	5.8
8-15	4.1	8.7	5.9
10-8	5.4	9.3	7.2
10-12	10.1	11.8	7.9

Please Note: The above data represents characteristic capacities obtained under laboratory conditions and are only applicable to Bremick products. The design professional must apply appropriate safety factors.





**GENERAL MECHANICAL PROPERTIES**  
**STAINLESS STEEL GRADE 304 BI-METAL SCREWS**  
**CHARACTERISTIC CAPACITIES**



TABLE 15

Fastener STAINLESS STEEL 304	SDM	Single Shear KN	Axial Tensile KN	Torsional Nm
10-16		4.2	7.2	6.1
12-14		5.7	9.7	8.8
12-24		6.6	11.3	9.4
14-14		7.9	13.4	11.6
14-24		9.6	16.4	15.0

**GENERAL MECHANICAL PROPERTIES**  
**STAINLESS STEEL GRADE 304 TYPE 17 SCREWS**  
**CHARACTERISTIC CAPACITIES**



TABLE 15

Fastener TYPE 17 & NEEDLE POINT STAINLESS STEEL 304	Single Shear KN	Axial Tensile KN	Torsional Nm
8-15	3.2	5.4	3.9
10-12	3.7	6.3	4.2
12-11	5.6	9.6	8.0
14-10	7.2	12.4	11.9

**GENERAL MECHANICAL PROPERTIES**  
**STAINLESS STEEL GRADE 316 TYPE 17 SCREWS**  
**CHARACTERISTIC CAPACITIES**



TABLE 15

Fastener TYPE 17 & NEEDLE POINT STAINLESS STEEL 316	Single Shear KN	Axial Tensile KN	Torsional Nm
10-12	3.7	6.3	4.2
14-10	7.2	12.4	11.9

Please Note: The above data represents characteristic capacities obtained under laboratory conditions and are only applicable to Bremick products. The design professional must apply appropriate safety factors.



### AXIAL WITHDRAWAL FORCES

VORTEX™ UNIVERSAL SCREWS FOR TIMBER & METAL  
CHARACTERISTIC CAPACITIES  
STEEL PURLINS AND STEEL SUPPORTS



TABLE 18

Fastener	Mean Ultimate Pull Out Force KN - Steel							
	1.0mm	1.2mm	1.5mm	1.9mm	2.4mm	3.0mm	4.0mm	8.0mm
	BMT G450	BMT G450	BMT G450	BMT G450	BMT G450	BMT G300	BMT G300	BMT G300
<b>VORTEX™</b>								
Vortex Stud M4.2	2.8	2.9	3.7	5.3				
Vortex Stud M5.4	2.8	3.2	3.8	5.5	6.6			
Vortex Mini	3.2	3.7	4.5	6.1				
Vortex Fibre M5	2.9	3.9	4.5	5.0				
Vortex Clad M5.4	2.8	3.2	4.0	5.5				
Vortex Clad M6.2	3.5	4.9	5.4	8.0				
Vortex Poly	3.5	4.9	5.4	8.0				
Vortex FibreGlass	2.8	3.2	4.0	5.5				
Vortex Roof	3.5	4.9	5.4	8.0	5.8	7.6	9.7	
Vortex Corri	3.5	4.9	5.4	8.0				
Vortex Cyclone	3.5	4.9	5.4	6.0				
Vortex Batten Fix	2.8	3.7	4.8	5.3				
Vortex Shed	2.6	3.2	4.0	7.3				
Vortex Stitch	3.9	4.7	5.9	8.5	7.7	9.0	12.2	
Vortex Truss	4.2	5.2	6.4					
					11.0	13.0	16.7	

### AXIAL WITHDRAWAL FORCES

VORTEX™ UNIVERSAL SCREWS FOR TIMBER & METAL  
CHARACTERISTIC CAPACITIES  
THIN METAL BATTENS AND METAL STUDS



TABLE 19

Fastener	Mean Ultimate Pull Out Force KN - Metal Battens						
	0.42mm	0.55mm	0.55mm	0.75mm	0.9mm	1.0mm	1.2mm
	BMT G550	BMT G450	BMT G550	BMT G550	BMT G550	BMT G550	BMT G550
<b>VORTEX™</b>							
Vortex Stud M4.2							
Vortex Stud M5.4	0.8	0.8	1.2	1.8	2.2	2.4	2.6
Vortex Mini	0.9	0.9	1.2	1.7	2.0	2.6	2.6
Vortex Fibre M5	1.2	1.2	1.4	2.3	2.9	3.3	2.6
Vortex Clad M5.4	1.0	1.0	1.2	2.0	2.6	3.0	3.3
Vortex Clad M6.2	0.9	0.9	1.2	1.7	2.0	2.6	3.0
Vortex Poly	1.5	1.5	2.0	2.5	3.1	3.5	2.6
Vortex FibreGlass	1.5	1.5	2.0	2.5	3.1	3.5	4.9
Vortex Roof	0.9	0.9	1.0	1.7	2.0	2.1	4.9
Vortex Corri	1.5	1.5	2.0	2.5	3.1	3.5	2.6
Vortex Cyclone	1.5	1.5	2.0	2.5	3.1	3.5	4.9
Vortex Batten Fix	1.5	1.5	2.0	2.5	3.1	3.5	4.9
Vortex Shed	0.9	0.9	1.5	2.1	2.5	2.8	4.9
Vortex Stitch	0.9	0.9	1.1	1.5	1.9	2.0	3.8
Vortex Truss	1.5	1.5	1.5	2.5	3.2	3.7	2.3
	1.5	1.5	1.5	2.5	3.3	3.8	3.8
							4.2

Please Note: The above data represents characteristic capacities obtained under laboratory conditions and are only applicable to Bremick products. The design professional must apply appropriate safety factors.



## AXIAL WITHDRAWAL FORCES

SELF DRILLING SCREWS FOR METAL - CHARACTERISTIC CAPACITIES  
STEEL PURLINS AND STEEL SUPPORTS



TABLE 20

Fastener SDM	Mean Ultimate Pull Out Force KN - Steel							
	1.0mm BMT G450	1.2mm BMT G450	1.5mm BMT G450	1.9mm BMT G450	2.4mm BMT G450	3.0mm BMT G300	4.0mm BMT G300	8.0mm BMT G300
6-18 6-18	2.0	2.5	3.3					
10-16	2.0	2.4	3.4	5.3	6.6			
10-24	2.5	2.9	3.7	5.2	6.7			
12-14	2.8	3.0	4.3	5.5	7.0			
12-24	2.4	2.8	3.5	5.5	5.8	7.2	9.8	
14-10	2.8	3.2	4.0	4.8	6.4	7.4	8.3	
14-14	2.4	2.8	3.9	6.4	8.4	7.6	9.7	
14-20	3.0	3.7	4.6	6.1	8.0	7.8	10.0	15.0
	2.8	3.6	4.5	5.8	7.6	9.8	12.0	
	2.6	3.4	4.3			9.2	12.8	
						9.4	12.5	

## AXIAL WITHDRAWAL FORCES

SELF DRILLING SCREWS FOR METAL - CHARACTERISTIC CAPACITIES  
THIN METAL BATTENS AND METAL STUDS

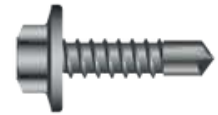

TABLE 21

Fastener VORTEX ™	Mean Ultimate Pull Out Force KN - Metal Battens						
	0.42mm BMT G550	0.55mm BMT G450	0.55mm BMT G550	0.75mm BMT G550	0.9mm BMT G550	1.0mm BMT G550	1.2mm BMT G550
8-18 8-20	0.8	0.8	1.1	1.2	1.3	1.6	2.0
8-18 10-16	0.8	0.8	0.9	1.1	1.2	1.3	2.2
16 10-24	0.8	0.8	1.2	1.8	2.2	2.4	2.6
12-14 12-24	0.9	0.9	1.0	1.8	2.1	2.2	2.6
24 14-10	0.8	0.8	1.1	1.8	2.1	2.3	2.5
14-14 14-20	0.9	0.9	1.0	1.7	2.0	2.1	2.6
	0.8	0.8	0.9	1.6	1.8	1.9	2.0
	1.1	1.1	1.1	1.8	2.1	2.5	2.7
	1.0	1.0	1.1	1.9	2.3	2.6	2.8
	0.8	0.8	1.1	1.9	2.4	2.7	2.9

## AXIAL WITHDRAWAL FORCES

NEEDLE POINT AND STITCHING SCREWS - CHARACTERISTIC CAPACITIES  
THIN METAL BATTENS AND METAL STUDS



TABLE 22

Fastener VORTEX ™	Mean Ultimate Pull Out Force KN - Metal Battens			
	0.42mm BMT G550	0.55mm BMT G450	0.55mm BMT G550	0.75mm BMT G550
7-16 8-10	0.8	0.8	1.1	1.3
8-15 10-8	1.2	1.2	1.4	1.6
10-12	1.3	1.3	1.4	1.6
	1.1	1.1	1.3	1.5
	1.3	1.3	1.5	1.7
	1.4	1.4	1.6	1.8
				2.0
				2.2
				2.4
				2.6
				2.8
				3.0

Please Note: The above data represents characteristic capacities obtained under laboratory conditions and are only applicable to Bremick products. The design professional must apply appropriate safety factors.



### AXIAL WITHDRAWAL FORCES

VORTEX™ UNIVERSAL SCREWS  
CHARACTERISTIC CAPACITIES  
F5/JD4 TIMBER (RADIATA PINE)



TABLE 23

Fastener VORTEX™	Mean Ultimate Pull Out in F5/JD4 Timber (Radiata Pine)					
	Embedment Depth					
	20mm	25mm	30mm	35mm	40mm	50mm
Vortex Mini Vortex	2.0	3.0				
Fibre M5 Vortex	1.8	2.8				
Clad M5.4 Vortex	2.5					
Clad M6.2 Vortex	2.7					
Poly Vortex Roof		3.1	4.7	6.2		
Vortex Cyclone		3.1	4.7	6.2		
Vortex Batten Fix		3.1	4.7	6.2		
Vortex Deck		2.6	4.3	6.3	8.3	
		2.5	3.1	4.5	5.5	

### AXIAL WITHDRAWAL FORCES

VORTEX™ UNIVERSAL SCREWS  
CHARACTERISTIC CAPACITIES  
F17/J3 HARDWOOD TIMBER



TABLE 24

Fastener VORTEX™	Mean Ultimate Pull Out in F17/J3 Timber					
	Embedment Depth					
	20mm	25mm	30mm	35mm	40mm	50mm
Vortex Mini Vortex	2.6	3.9				
Fibre M5 Vortex	2.3	3.7				
Clad M5.4 Vortex	3.6					
Clad M6.2 Vortex	3.7					
Poly Vortex Roof						
Vortex Cyclone		3.8	4.7	6.2		
Vortex Batten Fix		4.6	6.2	6.5		
Vortex Deck		4.6	6.2	6.5		
		4.1	6.5	7.4	8.4	
		3.2	4.1	5.6	6.8	

Please Note: The above data represents characteristic capacities obtained under laboratory conditions and are only applicable to Bremick products. The design professional must apply appropriate safety factors.



### AXIAL WITHDRAWAL FORCES

TYPE 17 SELF DRILLING SCREWS  
CHARACTERISTIC CAPACITIES  
F5/JD4 TIMBER (RADIATA PINE)



TABLE 25

Fastener TYPE	Mean Ultimate Pull Out in F5/JD4 Timber (Radiata Pine)						
	Embedment Depth						
	15mm	20mm	25mm	30mm	35mm	40mm	50mm
17	1.5	2.0					
6-18 8-	1.8	2.6					
10 8-15	1.7	2.6					
8-18 10-		3.0					
12 12-11		2.9	3.8	4.3	4.8		
14-10		2.6	3.8	4.6	5.6	6.5	
		4.5	4.0	4.3	6.3	7.2	
			6.0	6.5	6.9	7.6	9.1

### AXIAL WITHDRAWAL FORCES

TYPE 17 SELF DRILLING SCREWS  
CHARACTERISTIC CAPACITIES  
F17/J3 HARDWOOD TIMBER



TABLE 26

Fastener TYPE	Mean Ultimate Pull Out in F17/J3 Timber						
	Embedment Depth						
	15mm	20mm	25mm	30mm	35mm	40mm	50mm
17	2.6	3.5					
6-18 8-	2.7	4					
10 8-15	2.4	3.7					
8-18 10-		4.5					
12 12-11		3.8	5.7	6.0	7.0		
14-10		3.9	4.9	6.0	7.0	8.4	
		5.1	5.6	6.5	7.4	8.7	
			7.5	9.1	9.6	11.0	13.2

### AXIAL WITHDRAWAL FORCES

NEEDLE POINT SCREWS  
CHARACTERISTIC CAPACITIES  
F5/JD4 TIMBER (RADIATA PINE)



TABLE 27

Fastener NEEDLE POINT	Mean Ultimate Pull Out in F5/JD4 Timber (Radiata Pine)						
	Embedment Depth						
	15mm	20mm	25mm	30mm	35mm	40mm	50mm
6-18 8-10 8-15	1.6	2.0	2.4				
8-18 10-12 12-	1.8	2.4	2.6				
11 14-10	1.7	2.4	3.3				
	1.9	2.6	3.4				
	1.7	2.6	3.2				
	1.6	2.4	3.5	3.5	4.0		
	1.8			4.0	4.8		

Please Note: The above data represents characteristic capacities obtained under laboratory conditions and are only applicable to Bremick products. The design professional must apply appropriate safety factors.



**TECHNICAL SPECIFICATION: EPDM SEALING WASHERS**  
**EPDM (ETHYLENE PROPYLENE DIENE MONOMER)**  
**SEALING WASHERS**

*Bremick sealing washers are manufactured from resilient, low carbon, non conductive EPDM. Giving high sealing properties together with excellent resistance to chemical and UV exposure.*

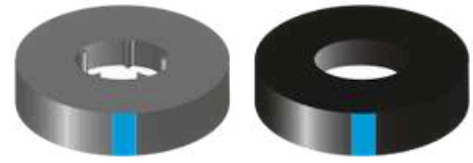

**PRODUCT RANGE: DEKSEAL TRUEBLUE**

**TABLE 28**

**AMERICAN STANDARD FOR TESTING OF MATERIALS (ASTM)**

ASTM Metho	Test Description	Specification	RESULTS	
			Grey EPDM	Black EPDM
	Shore "A" Hardness	80 +/-5	80	80
<b>D2240</b>	Tensile Strength (TS) (MPa min)	6.0 min	7.0	7.0
<b>D412</b>	Elongation @ Break (% min)	125 min	150	150
<b>D412</b>	Tear resistance Die C (KN/m Min.)	18.0 min	19.0	19.0
<b>D624</b>	Trouser Tear (KN/min)	2.5 min	3.5	3.5
<b>D573</b>	Heat Resistance 70 Hrs @ 100°C			
	Change in Hardness (Points)	+/- 10	3	3
	Change in Tensile (%)	+/- 25	-12	-1
	Change in Elongation (%)	+/- 50	-30	2
<b>D395</b>	Compression Set 22 Hrs @ 70°C (% Max)	25%	18.5	18.5
<b>D1171</b>	Resistance to Ozone	100 ppm, No cracks	Passed	Passed
<b>D2137</b>	Low Temp. Brittleness (3 mins @ -50°C)	Not brittle	Passed	Passed
<b>D257-07</b>	DC resistance and Conductivity, Application voltage & resistance to determine current flow	Max 0.5x10 <sup>-6</sup> A	Zero	Zero

**OTHER**

ASTM Method	Test Description	RESULTS	
		Grey EPDM	Black EPDM
<b>SAHB39 - 1997</b>	Installation Code for Metal Roofing and Walling	Approved	Approved
	Constant Temperature Resistance	-50 to 115°C	-50 to 115°C
	Intermittent Temperature Resistance	-50 to 220°C	-50 to 220°C



**RIVETS & SETTING TOOLS 12**

Rivet Packaging Options 6

Colour Coordination 12

**ALUMINIUM RIVETS 130 Aluminium 5056 - Truss Head & Countersunk Head 130 Aluminium 5052 -**

Truss Head 132 Aluminium 5052 - Large Flange

Head 133 All Aluminium 5052 - Truss 134

Aluminium 5052 - Multigrip 134

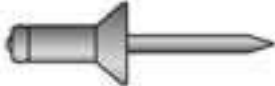
**ALUMINIUM 5056 SEALED RIVETS 135****ALUMINIUM PAINTED RIVETS 136**

Aluminium 5052- Truss 136

Aluminium 5052- Truss Trade Packs 141

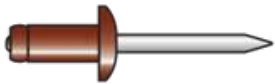
**RIVETS 146**

Steel 1010 - Truss 146

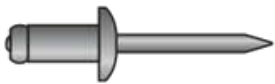
**MONEL® RIVETS 147**

MONEL® - Truss &amp; Countersunk Head 147

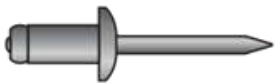
**STAINLESS STEEL RIVETS 149**

Stainless Steel 304 - Truss 149

All Stainless Steel 304 - Truss 149

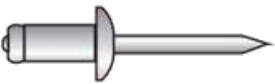
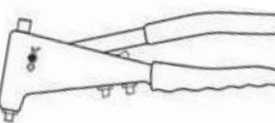
**RIVET SETTING TOOLS 150****RIVET TECHNICAL DATA 152**



### ALUMINIUM 5056 RIVETS STEEL STEM ZINC PLATED - TRUSS HEAD

Size	Rivet Diameter (mm)	Grip Range (mm)	Pack Quantity	Product Code
3-2	2.4	1.6-3.2	1000	RPTAS0302I2
3-3	2.4	3.2-4.8	1000	RPTAS0303I2
4-1	3.2	up to 1.6	1000	RPTAS0401I2
4-2	3.2	1.6-3.2	1000	RPTAS0402I2
4-3	3.2	3.2-4.8	1000	RPTAS0403I2
4-4	3.2	4.8-6.4	1000	RPTAS0404I2
4-5	3.2	6.4-8.0	1000	RPTAS0405I2
4-6	3.2	8.0-9.5	1000	RPTAS0406I2
4-8	3.2	9.5-12.7	1000	RPTAS0408I2
4-10	3.2	12.7-15.8	1000	RPTAS0410I2
4-12	3.2	15.8-19.0	500	RPTAS0412I2
5-1	4.0	up to 1.6	1000	RPTAS0501I2
5-2	4.0	1.6-3.2	1000	RPTAS0502I2
5-3	4.0	3.2-4.8	1000	RPTAS0503I2
5-4	4.0	4.8-6.4	1000	RPTAS0504I2
5-5	4.0	6.4-8.0	1000	RPTAS0505I2
5-6	4.0	8.0-9.5	500	RPTAS0506I2
5-8	4.0	9.5-12.7	500	RPTAS0508I2
6-1	4.8	up to 1.6	500	RPTAS0601I2
6-2	4.8	1.6-3.2	500	RPTAS0602I2
6-3	4.8	3.2-4.8	500	RPTAS0603I2
6-4	4.8	4.8-6.4	500	RPTAS0604I2
6-5	4.8	6.4-8.0	500	RPTAS0605I2
6-6	4.8	8.0-9.5	500	RPTAS0606I2
6-8	4.8	9.5-12.7	500	RPTAS0608I2
6-10	4.8	12.7-15.8	500	RPTAS0610I2
6-12	4.8	15.9-19.0	250	RPTAS0612I2
6-14	4.8	19.0-22.2	250	RPTAS0614I2
6-16	4.8	22.2-25.4	250	RPTAS0616I2
6-20	4.8	25.4-31.8	250	RPTAS0620I2
8-2	6.4	up to 3.2	250	RPTAS0802I2
8-4	6.4	3.2-6.4	250	RPTAS0804I2
8-6	6.4	6.4-9.5	250	RPTAS0806I2
8-8	6.4	9.5-12.7	250	RPTAS0808I2
8-10	6.4	12.7-15.8	250	RPTAS0810I2
8-12	6.4	15.9-19.0	250	RPTAS0812I2
8-14	6.4	19.0-22.2	250	RPTAS0814I2
8-16	6.4	22.2-25.4	250	RPTAS0816I2

#### INDUSTRY CODING COMPARISONS

SUPPLIER	CODE	SUPPLIER	CODE
BREMICK	RPTAS	POP	TAP D
AJAX	73 AS	MARSON	AB



Manufactured from 5052 Marine Grade Aluminium.



Manufactured from 5056 Marine Grade Aluminium.



## ALUMINIUM 5056 RIVETS STEEL STEM ZINC PLATED - COUNTERSUNK HEAD



Size	Rivet Diameter (mm)	Grip Range (mm)	Pack Quantity	Product Code
4-2	3.2	1.6-3.2	1000	RPKAS0402I
4-3	3.2	3.2-4.8	1000	RPKAS0403I2
4-4	3.2	4.8-6.4	1000	RPKAS0404I2
4-5	3.2	6.4-8.0	1000	RPKAS0405I2
4-6	3.2	8.0-9.5	1000	RPKAS0406I2
5-2	4.0	1.6-3.2	1000	RPKAS0502I2
5-3	4.0	3.2-4.8	1000	RPKAS0503I2
5-4	4.0	4.8-6.4	1000	RPKAS0504I2
5-5	4.0	6.4-8.0	1000	RPKAS0505I2
5-6	4.0	8.0-9.5	500	RPKAS0506I2
6-2	4.8	1.6-3.2	500	RPKAS0602I2
6-3	4.8	3.2-4.8	500	RPKAS0603I2
6-4	4.8	4.8-6.4	500	RPKAS0604I2
6-6	4.8	8.0-9.5	500	RPKAS0606I2
6-8	4.8	9.5-12.7	500	RPKAS0608I2
6-10	4.8	12.7-15.8	500	RPKAS0610I2

### INDUSTRY CODING COMPARISONS

SUPPLIER	CODE
BREMICK	RPKAS
AJAX	72 AS
POP	TAP K
MARSON	AC



Manufactured from 5052 Marine Grade Aluminium.



Manufactured from 5056 Marine Grade Aluminium.



### ALUMINIUM 5052 RIVETS STEEL STEM ZINC PLATED - TRUSS HEAD

Size	Rivet Diameter (mm)	Grip Range (mm)	Pack Quantity	Product Code
4-2	3.2	1.6-3.2	1000	RPT2S0402I2
4-3	3.2	3.2-4.8	1000	RPT2S0403I2
4-4	3.2	4.8-6.4	1000	RPT2S0404I2
4-5	3.2	6.4-8.0	1000	RPT2S0405I2
4-6	3.2	8.0-9.5	1000	RPT2S0406I2
4-8	3.2	9.5-12.7	1000	RPT2S0408I2
5-2	4.0	1.6-3.2	1000	RPT2S0502I2
5-3	4.0	3.2-4.8	1000	RPT2S0503I2
5-4	4.0	4.8-6.4	1000	RPT2S0504I2
5-5	4.0	6.4-8.0	1000	RPT2S0505I2
5-6	4.0	8.0-9.5	500	RPT2S0506I2
5-8	4.0	9.5-12.7	500	RPT2S0508I2
6-2	4.8	1.6-3.2	500	RPT2S0602I2
6-3	4.8	3.2-4.8	500	RPT2S0603I2
6-4	4.8	4.8-6.4	500	RPT2S0604I2
6-5	4.8	6.4-8.0	500	RPT2S0605I2
6-6	4.8	8.0-9.5	500	RPT2S0606I2
6-8	4.8	9.5-12.7	500	RPT2S0608I2
6-10	4.8	12.7-15.8	500	RPT2S0610I2

#### BENEFITS OF 5052 GRADE ALUMINIUM OVER GRADE 5056:

- Maximises hole filling
- Suitable for:
  - softer materials, eg plastics, thin aluminium etc (lower tensile strength rivet)
  - thinner materials in general

#### INDUSTRY CODING COMPARISONS

##### SUPPLIER

##### CODE

BREMICK RPT 2S



Manufactured from 5052  
Marine Grade Aluminium.



Manufactured from  
5056 Marine Grade  
Aluminium.



## ALUMINIUM 5052 LARGE FLANGE RIVETS STEEL STEM ZINC PLATED - FLANGE HEAD



Size	Rivet Diameter (mm)	Grip Range (mm)	Pack Quantity	Product Code
4-2	3.2	1.6-3.2	1000	RPFAS0402I2
4-4	3.2	4.8-6.4	1000	RPFAS0404I2
4-6	3.2	8.0-9.5	1000	RPFAS0406I2
4-8	3.2	9.5-12.7	1000	RPFAS0408I2
5-6	4.0	8.0-9.5	250	RPFAS0506I2
6-3	4.8	3.2-4.8	250	RPFAS0603I2
6-4	4.8	4.8-6.4	250	RPFAS0604I2
6-6	4.8	8.0-9.5	250	RPFAS0606I2
6-8	4.8	9.5-12.7	250	RPFAS0608I2
6-10	4.8	12.7-15.8	250	RPFAS0610I2
6-12	4.8	15.8-19.0	250	RPFAS0612I2
6-14	4.8	19.0-22.2	250	RPFAS0614I2
6-16	4.8	22.2-25.4	250	RPFAS0616I2

### INDUSTRY CODING COMPARISONS

SUPPLIER	CODE
BREMICK	RPFAS
AJAX	73 ASL
POP	TAP LF
MARSON	ABL



Manufactured from 5052 Marine Grade Aluminium.



Manufactured from 5056 Marine Grade Aluminium.



5052

### ALL ALUMINIUM 5052 RIVETS ALUMINIUM STEM - TRUSS HEAD

Size	Rivet Diameter (mm)	Grip Range (mm)	Pack Quantity	Product Code
4-2	3.2	1.6-3.2	1000	RPTAA0402I2
4-3	3.2	3.2-4.8	1000	RPTAA0403I2
4-4	3.2	4.8-6.4	1000	RPTAA0404I2
4-5	3.2	6.4-8.0	1000	RPTAA0405I2
4-6	3.2	8.0-9.5	1000	RPTAA0406I2
4-8	3.2	9.5-12.7	1000	RPTAA0408I2
4-10	3.2	12.7-15.8	1000	RPTAA0410I2
5-2	4.0	1.6-3.2	1000	RPTAA0502I2
5-4	4.0	4.8-6.4	1000	RPTAA0504I2
5-6	4.0	8.0-9.5	500	RPTAA0506I2
6-2	4.8	1.6-3.2	500	RPTAA0602I2
6-3	4.8	3.2-4.8	500	RPTAA0603I2
6-4	4.8	4.8-6.4	500	RPTAA0604I2
6-6	4.8	8.0-9.5	500	RPTAA0606I2
6-8	4.8	9.5-12.7	500	RPTAA0608I2
6-10	4.8	12.7-15.8	500	RPTAA0610I2

#### INDUSTRY CODING COMPARISONS

SUPPLIER	CODE
BREMICK	RPTAA
AJAX	73 AA

5052

Manufactured from  
5052 Marine Grade  
Aluminium.

5056

Manufactured from  
5056 Marine Grade  
Aluminium.



5052

### ALL ALUMINIUM 5052 MULTI-GRIP RIVETS

#### STEEL STEM ZINC PLATED - TRUSS HEAD

Size	Rivet Diameter (mm)	Grip Range (mm)	Pack Quantity	Product Code
4-1/3	3.2	1.0-5.5	1000	RMTAS0401I2
4-4/5	3.2	3.5-7.5	1000	RMTAS0404I2
5-1/4	4.0	1.0-6.5	1000	RMTAS0501I2
5-5/6	4.0	4.0-8.5	1000	RMTAS0505I2
6-1/4	4.8	1.0-6.4	500	RMTAS0601I2
6-5/7	4.8	4.5-9.5	500	RMTAS0604I2
6-7/8	4.8	6.5-11.5	500	RMTAS0607I2

#### INDUSTRY CODING COMPARISONS

SUPPLIER	CODE	SUPPLIER	CODE
BREMICK	RMTAS	MARSON	AB MG
AJAX	73 ASMG		

5052

Manufactured from  
5052 Marine Grade  
Aluminium.

5056

Manufactured from  
5056 Marine Grade  
Aluminium.



## STEEL STEM OIL FINISH - TRUSS HEAD

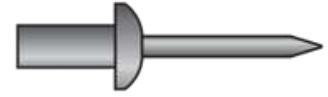

Size	Rivet Diameter (mm)	Grip Range (mm)	Pack Quantity	Product Code
4-1	3.2	up to 1.6	1000	RSTAS0401I2
4-2	3.2	1.6-3.2	1000	RSTAS0402I2
4-3	3.2	3.2-4.8	1000	RSTAS0403I2
4-4	3.2	4.8-6.4	1000	RSTAS0404I2
4-5	3.2	6.4-8.0	1000	RSTAS0405I2
4-6	3.2	8.0-9.5	1000	RSTAS0406I2
5-2	4.0	1.6-3.2	1000	RSTAS0502I2
5-3	4.0	3.2-4.8	1000	RSTAS0503I2
5-4	4.0	4.8-6.4	1000	RSTAS0504I2
5-5	4.0	6.4-8.0	1000	RSTAS0505I2
5-6	4.0	8.0-9.5	500	RSTAS0506I2
6-2	4.8	1.6-3.2	500	RSTAS0602I2
6-3	4.8	3.2-4.8	500	RSTAS0603I2
6-4	4.8	4.8-6.4	500	RSTAS0604I2
6-5	4.8	6.4-8.0	500	RSTAS0605I2
6-6	4.8	8.0-9.5	500	RSTAS0606I2
6-8	4.8	9.5-12.7	500	RSTAS0608I2
6-10	4.8	12.7-15.8	500	RSTAS0610I2

### INDUSTRY CODING COMPARISONS

SUPPLIER	CODE
BREMICK	RSTAS
AJAX	73 TA
POP	AD
MARSON	WP



Manufactured from 5052 Marine Grade Aluminium.



Manufactured from 5056 Marine Grade Aluminium.

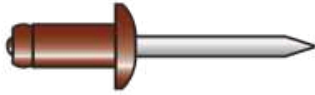

**ALUMINIUM 5052 PAINTED RIVETS - BULK PACKS**  
**STEEL STEM ZINC PLATED - TRUSS HEAD**  
**AUSTRALIAN ROOFING COLOURS**

Colour	Size	Rivet Diameter (mm)	Grip Range (mm)	Pack Quantity	Product Code
<b>Surfmist™</b>	4-2	3.2	1.6-3.2	1000	RCT2SSM4022
	4-3	3.2	3.2-4.8	1000	RCT2SSM4032
	4-4	3.2	4.8-6.4	1000	RCT2SSM4042
<b>Windspray™</b>	4-2	3.2	1.6-3.2	1000	RCT2SWS4022
	4-3	3.2	3.2-4.8	1000	RCT2SWS4032
	4-4	3.2	4.8-6.4	1000	RCT2SWS4042
<b>Wilderness™</b>	4-2	3.2	1.6-3.2	1000	RCT2SWI4022
	4-3	3.2	3.2-4.8	1000	RCT2SWI4032
	4-4	3.2	4.8-6.4	1000	RCT2SWI4042
<b>Headland™</b>	4-2	3.2	1.6-3.2	1000	RCT2SHL4022
	4-3	3.2	3.2-4.8	1000	RCT2SHL4032
	4-4	3.2	4.8-6.4	1000	RCT2SHL4042
<b>Deep Ocean™</b>	4-2	3.2	1.6-3.2	1000	RCT2SDO4022
	4-3	3.2	3.2-4.8	1000	RCT2SDO4032
	4-4	3.2	4.8-6.4	1000	RCT2SDO4042
<b>Dune™</b>	4-2	3.2	1.6-3.2	1000	RCT2SDU4022
	4-3	3.2	3.2-4.8	1000	RCT2SDU4032
	4-4	3.2	4.8-6.4	1000	RCT2SDU4042
<b>Classic Cream™</b>	4-2	3.2	1.6-3.2	1000	RCT2SCC4022
	4-3	3.2	3.2-4.8	1000	RCT2SCC4032
	4-4	3.2	4.8-6.4	1000	RCT2SCC4042
<b>Paperbank™</b>	4-2	3.2	1.6-3.2	1000	RCT2SPA4022
	4-3	3.2	3.2-4.8	1000	RCT2SPA4032
	4-4	3.2	4.8-6.4	1000	RCT2SPA4042
<b>Shale Grey™</b>	4-2	3.2	1.6-3.2	1000	RCT2SSH4022
	4-3	3.2	3.2-4.8	1000	RCT2SSH4032
	4-4	3.2	4.8-6.4	1000	RCT2SSH4042
<b>Woodland Grey™</b>	4-2	3.2	1.6-3.2	1000	RCT2SWG4022
	4-3	3.2	3.2-4.8	1000	RCT2SWG4032
	4-4	3.2	4.8-6.4	1000	RCT2SWG4042

™ Colour names are trademarks of BlueScope Steel Limited.

COLORBOND® is a registered trade mark of BlueScope Steel Limited.

Painted to order minimum quantity per size is 1000 pieces for non standard colours, please supply a colour sample, 30 x 30cm for colour matching.



Manufactured from  
5052 Marine Grade  
Aluminium.



Manufactured from  
5056 Marine Grade  
Aluminium.

## ALUMINIUM 5052 PAINTED RIVETS - BULK PACKS STEEL STEM ZINC PLATED - TRUSS HEAD AUSTRALIAN ROOFING COLOURS

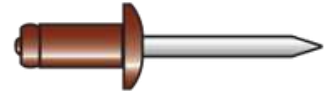

Colour	Size	Rivet Diameter (mm)	Grip Range (mm)	Pack Quantity	Product Code
<b>Pale Eucalypt™</b>	4-2	3.2	1.6-3.2	1000	RCT2SPE4022
	4-3	3.2	3.2-4.8	1000	RCT2SPE4032
	4-4	3.2	4.8-6.4	1000	RCT2SPE4042
<b>Cottage Green™</b>	4-2	3.2	1.6-3.2	1000	RCT2SCO4022
	4-3	3.2	3.2-4.8	1000	RCT2SCO4032
	4-4	3.2	4.8-6.4	1000	RCT2SCO4042
<b>Manor Red™</b>	4-2	3.2	1.6-3.2	1000	RCT2SMN4022
	4-3	3.2	3.2-4.8	1000	RCT2SMN4032
	4-4	3.2	4.8-6.4	1000	RCT2SMN4042
<b>Night Sky™</b>	4-2	3.2	1.6-3.2	1000	RCT2SNS4022
	4-3	3.2	3.2-4.8	1000	RCT2SNS4032
	4-4	3.2	4.8-6.4	1000	RCT2SNS4042
<b>Bushland™</b>	4-2	3.2	1.6-3.2	1000	RCT2SBD4022
	4-3	3.2	3.2-4.8	1000	RCT2SBD4032
	4-4	3.2	4.8-6.4	1000	RCT2SBD4042
<b>Plantation™</b>	4-2	3.2	1.6-3.2	1000	RCT2SPL4022
	4-3	3.2	3.2-4.8	1000	RCT2SPL4032
	4-4	3.2	4.8-6.4	1000	RCT2SPL4042
<b>Ironstone™</b>	4-2	3.2	1.6-3.2	1000	RCT2SIS4022
	4-3	3.2	3.2-4.8	1000	RCT2SIS4032
	4-4	3.2	4.8-6.4	1000	RCT2SIS4042
<b>Sandbank™</b>	4-2	3.2	1.6-3.2	1000	RCT2SSK4022
	4-3	3.2	3.2-4.8	1000	RCT2SSK4032
	4-4	3.2	4.8-6.4	1000	RCT2SSK4042
<b>Blue Ridge™</b>	4-2	3.2	1.6-3.2	1000	RCT2SBI4022
	4-3	3.2	3.2-4.8	1000	RCT2SBI4032
	4-4	3.2	4.8-6.4	1000	RCT2SBI4042
<b>Jasper™</b>	4-2	3.2	1.6-3.2	1000	RCT2SJA4022
	4-3	3.2	3.2-4.8	1000	RCT2SJA4032
	4-4	3.2	4.8-6.4	1000	RCT2SJA4042

™ Colour names are trademarks of BlueScope Steel Limited.

COLORBOND® is a registered trade mark of BlueScope Steel Limited.



Manufactured from 5052 Marine Grade Aluminium.



Manufactured from 5056 Marine Grade Aluminium.

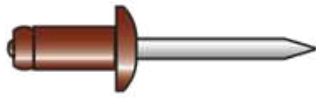

**ALUMINIUM 5052 PAINTED RIVETS - BULK PACKS**  
**STEEL STEM ZINC PLATED - TRUSS HEAD**  
**AUSTRALIAN FENCING COLOURS**

Colour (Roofing)	Size	Rivet Diameter (mm)	Grip Range (mm)	Pack Quantity	Product Code
<b>Teatree™</b> (Bushland™)	4-2	3.2	1.6-3.2	1000	RCT2SBD4022
	4-3	3.2	3.2-4.8	1000	RCT2SBD4032
	4-4	3.2	4.8-6.4	1000	RCT2SBD4042
<b>Evergreen™</b> (Cottage Green™)	4-2	3.2	1.6-3.2	1000	RCT2SCO4022
	4-3	3.2	3.2-4.8	1000	RCT2SCO4032
	4-4	3.2	4.8-6.4	1000	RCT2SCO4042
<b>Domain™</b>	4-2	3.2	1.6-3.2	1000	RCT2SDM4022
	4-3	3.2	3.2-4.8	1000	RCT2SDM4032
	4-4	3.2	4.8-6.4	1000	RCT2SDM4042
<b>Bluestone™</b> (Deep Ocean™)	4-2	3.2	1.6-3.2	1000	RCT2SDO4022
	4-3	3.2	3.2-4.8	1000	RCT2SDO4032
	4-4	3.2	4.8-6.4	1000	RCT2SDO4042
<b>Estate™</b>	4-2	3.2	1.6-3.2	1000	RCT2SES4022
	4-3	3.2	3.2-4.8	1000	RCT2SES4032
	4-4	3.2	4.8-6.4	1000	RCT2SES4042
<b>Harvest™</b>	4-2	3.2	1.6-3.2	1000	RCT2SHA4022
	4-3	3.2	3.2-4.8	1000	RCT2SHA4032
	4-4	3.2	4.8-6.4	1000	RCT2SHA4042
<b>Red Oak™</b> (Manor Red™)	4-2	3.2	1.6-3.2	1000	RCT2SMN4022
	4-3	3.2	3.2-4.8	1000	RCT2SMN4032
	4-4	3.2	4.8-6.4	1000	RCT2SMN4042
<b>Terrace™</b> (Paperbark™)	4-2	3.2	1.6-3.2	1000	RCT2SPA4022
	4-3	3.2	3.2-4.8	1000	RCT2SPA4032
	4-4	3.2	4.8-6.4	1000	RCT2SPA4042
<b>Meadow™</b> (Pale Eucalypt™)	4-2	3.2	1.6-3.2	1000	RCT2SPE4022
	4-3	3.2	3.2-4.8	1000	RCT2SPE4032
	4-4	3.2	4.8-6.4	1000	RCT2SPE4042
<b>Hedge™</b> (Plantation™)	4-2	3.2	1.6-3.2	1000	RCT2SPL4022
	4-3	3.2	3.2-4.8	1000	RCT2SPL4032
	4-4	3.2	4.8-6.4	1000	RCT2SPL4042
<b>Riversand™</b>	4-2	3.2	1.6-3.2	1000	RCT2SRS4022
	4-3	3.2	3.2-4.8	1000	RCT2SRS4032
	4-4	3.2	4.8-6.4	1000	RCT2SRS4042
<b>Summershade™</b>	4-2	3.2	1.6-3.2	1000	RCT2SSS4022
	4-3	3.2	3.2-4.8	1000	RCT2SSS4032
	4-4	3.2	4.8-6.4	1000	RCT2SSS4042
<b>Grey Ridge™</b> (Woodland Grey™)	4-2	3.2	1.6-3.2	1000	RCT2SWG4022
	4-3	3.2	3.2-4.8	1000	RCT2SWG4032
	4-4	3.2	4.8-6.4	1000	RCT2SWG4042
<b>Willow™</b> (Wilderness™)	4-2	3.2	1.6-3.2	1000	RCT2SWI4022
	4-3	3.2	3.2-4.8	1000	RCT2SWI4032
	4-4	3.2	4.8-6.4	1000	RCT2SWI4042

™ Colour names are trademarks of BlueScope Steel Limited.  
 COLORBOND® is a registered trade mark of BlueScope Steel Limited.

**ALUMINIUM 5052 PAINTED RIVETS - BULK PACKS**  
**STEEL STEM ZINC PLATED - TRUSS HEAD**  
**NEW ZEALAND ROOFING COLOURS**

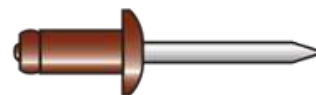

Colour	Size	Rivet Diameter (mm)	Grip Range (mm)	Pack Quantity	Min. Order Packs	Product Code
Azure	4-3	3.2	3.2-4.8	1000	1	RCT2SAZ4032
	5-3	4.0	3.2-4.8	1000	1	RCT2SAZ5032
Bone White	4-3	3.2	3.2-4.8	1000	1	RCT2SBW4032
	5-3	4.0	3.2-4.8	1000	1	RCT2SBW5032
Cloud	4-3	3.2	3.2-4.8	1000	1	RCT2SCD4032
	5-3	4.0	3.2-4.8	1000	1	RCT2SCD5032
Desert Sand	4-3	3.2	3.2-4.8	1000	1	RCT2SDE4032
	5-3	4.0	3.2-4.8	1000	1	RCT2SDE5032
Ebony	4-3	3.2	3.2-4.8	1000	1	RCT2SNS4032
	5-3	4.0	3.2-4.8	1000	1	RCT2SNS5032
Foam	4-3	3.2	3.2-4.8	1000	1	RCT2SFO4032
	5-3	4.0	3.2-4.8	1000	1	RCT2SFO5032
Gable Green	4-3	3.2	3.2-4.8	1000	1	RCT2SGA4032
	5-3	4.0	3.2-4.8	1000	1	RCT2SGA5032
Grey Friars	4-3	3.2	3.2-4.8	1000	1	RCT2SGF4032
	5-3	4.0	3.2-4.8	1000	1	RCT2SGF5032
Gull Grey	4-3	3.2	3.2-4.8	1000	1	RCT2SSH4032
	5-3	4.0	3.2-4.8	1000	1	RCT2SSH5032
Indigo Blue	4-3	3.2	3.2-4.8	1000	1	RCT2SIU4032
	5-3	4.0	3.2-4.8	1000	1	RCT2SIU5032
Ironsand	4-3	3.2	3.2-4.8	1000	1	RCT2SIR4032
	5-3	4.0	3.2-4.8	1000	1	RCT2SIR5032
Invorie	4-3	3.2	3.2-4.8	1000	1	RCT2SIV4032
	5-3	4.0	3.2-4.8	1000	1	RCT2SIV5032
Karaka	4-3	3.2	3.2-4.8	1000	1	RCT2SKA4032
	5-3	4.0	3.2-4.8	1000	1	RCT2SKA5032
Kelp	4-3	3.2	3.2-4.8	1000	1	RCT2SKE4032
	5-3	4.0	3.2-4.8	1000	1	RCT2SKE5032
Lichen	4-3	3.2	3.2-4.8	1000	1	RCT2SLI4032
	5-3	4.0	3.2-4.8	1000	1	RCT2SLI5032
Lignite	4-3	3.2	3.2-4.8	1000	1	RCT2SLN4032
	5-3	4.0	3.2-4.8	1000	1	RCT2SLN5032
Maple	4-3	3.2	3.2-4.8	1000	1	RCT2SHL4032
	5-3	4.0	3.2-4.8	1000	1	RCT2SHL5032

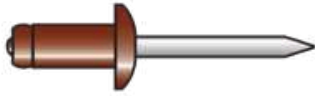

**ALUMINIUM 5052 PAINTED RIVETS - BULK PACKS**  
**STEEL STEM ZINC PLATED - TRUSS HEAD**  
**NEW ZEALAND ROOFING COLOURS**

Colour	Size	Rivet Diameter (mm)	Grip Range (mm)	Pack Quantity		Product Code
Mirage	4-3	3.2	3.2-4.8	1000	1	RCT2SMI4032
	5-3	4.0	3.2-4.8	1000	1	RCT2SMI5032
Mist Green	4-3	3.2	3.2-4.8	1000	1	RCT2SPE4032
	5-3	4.0	3.2-4.8	1000	1	RCT2SPE5032
New Blue Denim	4-3	3.2	3.2-4.8	1000	1	RCT2SDB4032
	5-3	4.0	3.2-4.8	1000	1	RCT2SDB5032
Pacific Blue	4-3	3.2	3.2-4.8	1000	1	RCT2SBI4032
	5-3	4.0	3.2-4.8	1000	1	RCT2SBI5032
Permanent Green	4-3	3.2	3.2-4.8	1000	1	RCT2SCO4032
	5-3	4.0	3.2-4.8	1000	1	RCT2SCO5032
Pioneer Red	4-3	3.2	3.2-4.8	1000	1	RCT2SPI4032
	5-3	4.0	3.2-4.8	1000	1	RCT2SPI5032
River Gum	4-3	3.2	3.2-4.8	1000	1	RCT2SWI4032
	5-3	4.0	3.2-4.8	1000	1	RCT2SWI5032
Sandstone Grey	4-3	3.2	3.2-4.8	1000	1	RCT2SSR4032
	5-3	4.0	3.2-4.8	1000	1	RCT2SSR5032
Scoria	4-3	3.2	3.2-4.8	1000	1	RCT2SMN4032
	5-3	4.0	3.2-4.8	1000	1	RCT2SMN5032
Smokey	4-3	3.2	3.2-4.8	1000	1	RCT2SWS4032
	5-3	4.0	3.2-4.8	1000	1	RCT2SWS5032
Smooth Cream	4-3	3.2	3.2-4.8	1000	1	RCT2SCC4032
	5-3	4.0	3.2-4.8	1000	1	RCT2SCC5032
Sorrell	4-3	3.2	3.2-4.8	1000	1	RCT2SJA4032
	5-3	4.0	3.2-4.8	1000	1	RCT2SJA5032
Spring Green	4-3	3.2	3.2-4.8	1000	1	RCT2SSP4032
	5-3	4.0	3.2-4.8	1000	1	RCT2SSP5032
Stone	4-3	3.2	3.2-4.8	1000	1	RCT2SRS4032
	5-3	4.0	3.2-4.8	1000	1	RCT2SRS5032
Storm Blue	4-3	3.2	3.2-4.8	1000	1	RCT2SDO4032
	5-3	4.0	3.2-4.8	1000	1	RCT2SDO5032
Straw	4-3	3.2	3.2-4.8	1000	1	RCT2SSK4032
	5-3	4.0	3.2-4.8	1000	1	RCT2SSK5032
Terracotta	4-3	3.2	3.2-4.8	1000	1	RCT2STC4032
	5-3	4.0	3.2-4.8	1000	1	RCT2STC5032
Thunder Grey	4-3	3.2	3.2-4.8	1000	1	RCT2SWG4032
	5-3	4.0	3.2-4.8	1000	1	RCT2SWG5032
Ti tania	4-3	3.2	3.2-4.8	1000	1	RCT2SSM4032
	5-3	4.0	3.2-4.8	1000	1	RCT2SSM5032



**ALUMINIUM 5052 RIVETS - TRADE PACKS**  
**STEEL STEM ZINC PLATED - TRUSS HEAD**

5052

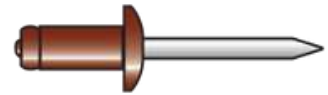

Bremick Fasteners now stock rivets in Plastic Trade Packs containing 100 pieces of Aluminium 5052 - Zinc Plated Steel Stem Truss Head Rivets.

The Trade Pack boxes are purpose designed, robust, resealable packs with hinged lids complete with easy lock closing clamps. Making them the ideal solution for efficient and tidy storage in any Tradesmans tool box or workshop.

The plastic Trade Packs are of unique modular design giving high shelf densities and the perfect presentation in any retail environment.

For your convenience each pack is individually labeled with product information , manufacturing batch number and Bar Code. For easy recognition of painted rivet colours each pack of painted rivets is supplied with the Bremick Colour Swatch label giving full colour name and visual colour recognition.



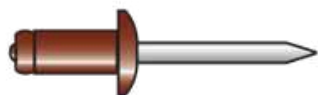

**ALUMINIUM 5052 PAINTED RIVETS - TRADE PACKS**  
**STEEL STEM ZINC PLATED - TRUSS HEAD**  
**COLOURS TO MATCH COLORBOND® ROOFING STEEL**

Colour	Size	Rivet Diameter (mm)	Grip Range (mm)	Pack Quantity	Product Code
Plain	4-3	3.2	3.2-4.8	100	RPT2S0403P2
Bushland™	4-3	3.2	3.2-4.8	100	RCT2SBD403P
Blue Ridge™	4-3	3.2	3.2-4.8	100	RCT2SBI403P
Classic Cream™	4-3	3.2	3.2-4.8	100	RCT2SCC403P
Classic Cream™	4-3	3.2	3.2-4.8	100	RCT2SCO403P
Deep Ocean™	4-3	3.2	3.2-4.8	100	RCT2SDO403P
Dune™	4-3	3.2	3.2-4.8	100	RCT2SDU403P
Headland™	4-3	3.2	3.2-4.8	100	RCT2SHL403P
Ironstone™	4-3	3.2	3.2-4.8	100	RCT2SIS403P
Jasper™	4-3	3.2	3.2-4.8	100	RCT2SJA403P
Manor Red™	4-3	3.2	3.2-4.8	100	RCT2SMN403P
Night Sky™	4-3	3.2	3.2-4.8	100	RCT2SNS403P
Paperbark™	4-3	3.2	3.2-4.8	100	RCT2SPA403P
Pale Eucalypt™	4-3	3.2	3.2-4.8	100	RCT2SPE403P
Plantation™	4-3	3.2	3.2-4.8	100	RCT2SPL403P
Shale Grey™	4-3	3.2	3.2-4.8	100	RCT2SSH403P
Sandbank™	4-3	3.2	3.2-4.8	100	RCT2SSK403P
Surfmist™	4-3	3.2	3.2-4.8	100	RCT2SSM403P
Woodland Grey™	4-3	3.2	3.2-4.8	100	RCT2SWG403P
Wilderness™	4-3	3.2	3.2-4.8	100	RCT2SWI403P
Windspray™	4-3	3.2	3.2-4.8	100	RCT2SWS403P

™ Colour names are trademarks of BlueScope Steel Limited.

COLORBOND® is a registered trade mark of BlueScope Steel Limited.



Manufactured from  
5052 Marine Grade  
Aluminium.



Manufactured from  
5056 Marine Grade  
Aluminium.

## ALUMINIUM 5052 PAINTED RIVETS - TRADE PACKS

STEEL STEM ZINC PLATED - TRUSS HEAD

COLOURS TO MATCH COLORBOND® FENCING STEEL

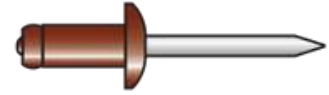

Colour	Size	Rivet Diameter (mm)	Grip Range (mm)	Pack Quantity	Product Code
Plain	4-3	3.2	3.2-4.8	100	RPT2S0403P2
Teatree™	4-3	3.2	3.2-4.8	100	RCT2SBD403P
Evergreen™	4-3	3.2	3.2-4.8	100	RCT2SCO403P
Domain™	4-3	3.2	3.2-4.8	100	RCT2SDM403P
Bluestone™	4-3	3.2	3.2-4.8	100	RCT2SDO403P
Estate™	4-3	3.2	3.2-4.8	100	RCT2SES403P
Harvest™	4-3	3.2	3.2-4.8	100	RCT2SHA403P
Red Oak™	4-3	3.2	3.2-4.8	100	RCT2SMN403P
Terrace™	4-3	3.2	3.2-4.8	100	RCT2SPA403P
Meadow™	4-3	3.2	3.2-4.8	100	RCT2SPE403P
Hedge™	4-3	3.2	3.2-4.8	100	RCT2SPL403P
Riversand™	4-3	3.2	3.2-4.8	100	RCT2SRS403P
Summershade™	4-3	3.2	3.2-4.8	100	RCT2SSS403P
Grey Ridge™	4-3	3.2	3.2-4.8	100	RCT2SWG403P
Willow™	4-3	3.2	3.2-4.8	100	RCT2SWI403P



Manufactured from 5052 Marine Grade Aluminium.



Manufactured from 5056 Marine Grade Aluminium.

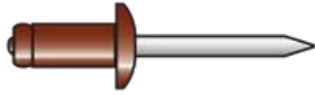

**ALUMINIUM 5052 PAINTED RIVETS - BULK PACKS**  
**STEEL STEM ZINC PLATED - TRUSS HEAD**  
**NEW ZEALAND COLOUR PALETTE**

Colour	Size	Rivet Diameter (mm)	Grip Range (mm)	Pack Quantity	Min. Order Packs	Product Code
Plain	4-3	3.2	3.2-4.8	100	1	RPT2S0403P2
	5-3	4.0	3.2-4.8	100	1	RPT2S0503P2
Azure	4-3	3.2	3.2-4.8	100	10	RCT2SAZ403P
	5-3	4.0	3.2-4.8	100	10	RCT2SAZ503P
Bone White	4-3	3.2	3.2-4.8	100	10	RCT2SBW403P
	5-3	4.0	3.2-4.8	100	10	RCT2SBW503P
Cloud	4-3	3.2	3.2-4.8	100	10	RCT2SCD403P
	5-3	4.0	3.2-4.8	100	10	RCT2SCD503P
Desert Sand	4-3	3.2	3.2-4.8	100	1	RCT2SDE403P
	5-3	4.0	3.2-4.8	100	1	RCT2SDE503P
Ebony	4-3	3.2	3.2-4.8	100	1	RCT2SNS403P
	5-3	4.0	3.2-4.8	100	1	RCT2SNS503P
Foam	4-3	3.2	3.2-4.8	100	10	RCT2SFO403P
	5-3	4.0	3.2-4.8	100	10	RCT2SFO503P
Gable Green	4-3	3.2	3.2-4.8	100	10	RCT2SGA403P
	5-3	4.0	3.2-4.8	100	10	RCT2SGA503P
Grey Friars	4-3	3.2	3.2-4.8	100	1	RCT2SGF403P
	5-3	4.0	3.2-4.8	100	1	RCT2SGF503P
Gull Grey	4-3	3.2	3.2-4.8	100	1	RCT2SSH403P
	5-3	4.0	3.2-4.8	100	1	RCT2SSH503P
Indigo Blue	4-3	3.2	3.2-4.8	100	10	RCT2SIU403P
	5-3	4.0	3.2-4.8	100	10	RCT2SIU503P
Ironsand	4-3	3.2	3.2-4.8	100	1	RCT2SIR403P
	5-3	4.0	3.2-4.8	100	1	RCT2SIR503P
Inverie	4-3	3.2	3.2-4.8	100	10	RCT2SIV403P
	5-3	4.0	3.2-4.8	100	10	RCT2SIV503P
Karaka	4-3	3.2	3.2-4.8	100	1	RCT2SKA403P
	5-3	4.0	3.2-4.8	100	1	RCT2SKA503P
Kelp	4-3	3.2	3.2-4.8	100	10	RCT2SKE403P
	5-3	4.0	3.2-4.8	100	10	RCT2SKE503P
Lichen	4-3	3.2	3.2-4.8	100	1	RCT2SLI403P
	5-3	4.0	3.2-4.8	100	1	RCT2SLI503P
Lignite	4-3	3.2	3.2-4.8	100	1	RCT2SLN403P
	5-3	4.0	3.2-4.8	100	1	RCT2SLN503P
Maple	4-3	3.2	3.2-4.8	100	1	RCT2SHL403P
	5-3	4.0	3.2-4.8	100	10	RCT2SHL503P
Mirage	4-3	3.2	3.2-4.8	100	10	RCT2SMI403P
	5-3	4.0	3.2-4.8	100	10	RCT2SMI503P
Mist Green	4-3	3.2	3.2-4.8	100	1	RCT2SPE403P
	5-3	4.0	3.2-4.8	100	1	RCT2SPE503P
New Blue Denim	4-3	3.2	3.2-4.8	100	1	RCT2SDB403P
	5-3	4.0	3.2-4.8	100	1	RCT2SDB503P

## ALUMINIUM 5052 PAINTED RIVETS - BULK PACKS STEEL STEM ZINC PLATED - TRUSS HEAD NEW ZEALAND COLOUR PALETTE (CONT)

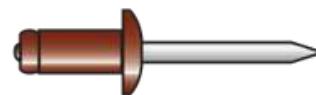

Colour	Size	Rivet Diameter (mm)	Grip Range (mm)	Pack Quantity	Min. Order Packs	Product Code
Pacific Blue	4-3	3.2	3.2-4.8	100	1	RCT2SBI403P
	5-3	4.0	3.2-4.8	100	10	RCT2SBI503P
Permanent Green	4-3	3.2	3.2-4.8	100	1	RCT2SCO403P
	5-3	4.0	3.2-4.8	100	1	RCT2SCO503P
Pioneer Red	4-3	3.2	3.2-4.8	100	1	RCT2SPI403P
	5-3	4.0	3.2-4.8	100	1	RCT2SPI503P
River Gum	4-3	3.2	3.2-4.8	100	1	RCT2SWI403P
	5-3	4.0	3.2-4.8	100	1	RCT2SWI503P
Sandstone Grey	4-3	3.2	3.2-4.8	100	1	RCT2SSR403P
	5-3	4.0	3.2-4.8	100	1	RCT2SSR503P
Scoria	4-3	3.2	3.2-4.8	100	1	RCT2SMN403P
	5-3	4.0	3.2-4.8	100	1	RCT2SMN503P
Smokey	4-3	3.2	3.2-4.8	100	1	RCT2SWS403P
	5-3	4.0	3.2-4.8	100	10	RCT2SWS503P
Smooth Cream	4-3	3.2	3.2-4.8	100	1	RCT2SCC403P
	5-3	4.0	3.2-4.8	100	10	RCT2SCC503P
Sorrell	4-3	3.2	3.2-4.8	100	1	RCT2SJA403P
	5-3	4.0	3.2-4.8	100	10	RCT2SJA503P
Spring Green	4-3	3.2	3.2-4.8	100	10	RCT2SSP403P
	5-3	4.0	3.2-4.8	100	10	RCT2SSP503P
Stone	4-3	3.2	3.2-4.8	100	1	RCT2SRS403P
	5-3	4.0	3.2-4.8	100	10	RCT2SRS503P
Storm Blue	4-3	3.2	3.2-4.8	100	1	RCT2SDO403P
	5-3	4.0	3.2-4.8	100	10	RCT2SDO503P
Straw	4-3	3.2	3.2-4.8	100	1	RCT2SSK403P
	5-3	4.0	3.2-4.8	100	10	RCT2SSK503P
Terracotta	4-3	3.2	3.2-4.8	100	1	RCT2STC403P
	5-3	4.0	3.2-4.8	100	1	RCT2STC503P
Thunder Grey	4-3	3.2	3.2-4.8	100	1	RCT2SWG403P
	5-3	4.0	3.2-4.8	100	10	RCT2SWG503P
Titania	4-3	3.2	3.2-4.8	100	1	RCT2SSM403P
	5-3	4.0	3.2-4.8	100	1	RCT2SSM503P

™ Colour names are trademarks of BlueScope Steel Limited.  
COLORBOND® is a registered trade mark of BlueScope Steel Limited.

**STEEL 1010 RIVETS - ZINC PLATED**  
**STEEL STEM ZINC PLATED - TRUSS HEAD**

Size	Rivet Diameter (mm)	Grip Range (mm)	Pack Quantity	Product Code
4-1	3.2	up to 1.6	1000	RPTSS0401I2
4-2	3.2	1.6-3.2	1000	RPTSS0402I2
4-3	3.2	3.2-4.8	1000	RPTSS0403I2
4-4	3.2	4.8-6.4	1000	RPTSS0404I2
4-5	3.2	6.4-8.0	1000	RPTSS0405I2
4-6	3.2	8.0-9.5	1000	RPTSS0406I2
4-8	3.2	9.5-12.7	1000	RPTSS0408I2
5-1	4.0	up to 1.6	1000	RPTSS0501I2
5-2	4.0	1.6-3.2	1000	RPTSS0502I2
5-3	4.0	3.2-4.8	1000	RPTSS0503I2
5-4	4.0	4.8-6.4	1000	RPTSS0504I2
5-5	4.0	6.4-8.0	1000	RPTSS0505I2
5-6	4.0	8.0-9.5	500	RPTSS0506I2
5-8	4.0	9.5-12.7	500	RPTSS0508I2
6-1	4.8	up to 1.6	500	RPTSS0601I2
6-2	4.8	1.6-3.2	500	RPTSS0602I2
6-3	4.8	3.2-4.8	500	RPTSS0603I2
6-4	4.8	4.8-6.4	500	RPTSS0604I2
6-5	4.8	6.4-8.0	500	RPTSS0605I2
6-6	4.8	8.0-9.5	500	RPTSS0606I2
6-8	4.8	9.5-12.7	500	RPTSS0608I2
6-10	4.8	12.7-15.8	500	RPTSS0610I2
8-2	6.4	up to 3.2	250	RPTSS0802I2
8-4	6.4	3.2-6.4	250	RPTSS0804I2
8-6	6.4	6.4-9.5	250	RPTSS0806I2
8-8	6.4	9.5-12.7	250	RPTSS0808I2

**INDUSTRY CODING COMPARISONS**

SUPPLIER	CODE
BREMICK	RPTSS
AJAX	73 SS
POP	TSP D
MARSON	SB



**MONEL® - STEEL STEM ZINC PLATED  
TRUSS HEAD**

Size	Rivet Diameter (mm)	Grip Range (mm)	Pack Quantity	Product Code
<b>4-1</b>	3.2	up to 1.6	1000	RPTMS0401I2
<b>4-2</b>	3.2	1.6-3.2	1000	RPTMS0402I2
<b>4-3</b>	3.2	3.2-4.8	1000	RPTMS0403I2
<b>4-4</b>	3.2	4.8-6.4	1000	RPTMS0404I2
<b>4-5</b>	3.2	6.4-8.0	1000	RPTMS0405I2
<b>4-6</b>	3.2	8.0-9.5	1000	RPTMS0406I2
<b>5-1</b>	4.0	up to 1.6	1000	RPTMS0501I2
<b>5-2</b>	4.0	1.6-3.2	1000	RPTMS0502I2
<b>5-3</b>	4.0	3.2-4.8	1000	RPTMS0503I2
<b>5-4</b>	4.0	4.8-6.4	1000	RPTMS0504I2
<b>5-5</b>	4.0	6.4-8.0	1000	RPTMS0505I2
<b>5-6</b>	4.0	8.0-9.5	500	RPTMS0506I2
<b>6-1</b>	4.8	up to 1.6	500	RPTMS0601I2
<b>6-2</b>	4.8	1.6-3.2	500	RPTMS0602I2
<b>6-3</b>	4.8	3.2-4.8	500	RPTMS0603I2
<b>6-4</b>	4.8	4.8-6.4	500	RPTMS0604I2
<b>6-5</b>	4.8	6.4-8.0	500	RPTMS0605I2
<b>6-6</b>	4.8	8.0-9.5	500	RPTMS0606I2
<b>6-8</b>	4.8	9.5-12.7	500	RPTMS0608I2
<b>6-10</b>	4.8	12.7-15.8	500	RPTMS0610I2
<b>8-4</b>	6.4	3.2-6.4	250	RPTMS0804I2
<b>8-6</b>	6.4	6.4-9.5	250	RPTMS0806I2
<b>8-8</b>	6.4	9.5-12.7	250	RPTMS0808I2

**INDUSTRY CODING COMPARISONS**

SUPPLIER	CODE
BREMICK	RPTMS
AJAX	73 MS
POP	TLP D
MARSON	MB

MONEL® is a registered trade mark of INCO.



**MONEL® - STEEL STEM ZINC PLATED  
COUNTERSUNK HEAD**

Size	Rivet Diameter (mm)	Grip Range (mm)	Pack Quantity	Product Code
<b>4-2</b>	3.2	1.6-3.2	1000	RPKMS0402I2
<b>4-4</b>	3.2	4.8-6.4	1000	RPKMS0404I2
<b>5-4</b>	4.0	4.8-6.4	1000	RPKMS0504I2
<b>6-2</b>	4.8	1.6-3.2	500	RPKMS0602I2
<b>6-3</b>	4.8	3.2-4.8	500	RPKMS0603I2
<b>6-4</b>	4.8	4.8-6.4	500	RPKMS0604I2
<b>6-5</b>	4.8	6.4-8.0	500	RPKMS0605I2
<b>6-6</b>	4.8	8.0-9.5	500	RPKMS0606I2
<b>6-8</b>	4.8	9.5-12.7	500	RPKMS0608I2

**INDUSTRY CODING COMPARISONS**

SUPPLIER	CODE
BREMICK	RPKMS
AJAX	72 MS
POP	TLP K
MARSON	MC

MONEL® is a registered trade mark of INCO.

STAINLESS STEEL 304 RIVETS

STEEL STEM ZINC PLATED - TRUSS HEAD

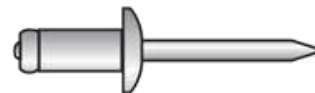

Size	Rivet Diameter (mm)	Grip Range (mm)	Pack Quantity	Product Code
4-	3.2	1.6-3.2	1000	RPT4S0402I2
	3.2	3.2-4.8	1000	RPT4S0403I2
2	3.2	4.8-6.4	1000	RPT4S0404I2
	3.2	8.0-9.5	1000	RPT4S0406I2
4-	4.0	1.6-3.2	1000	RPT4S0502I2
4-	4.0	4.8-6.4	1000	RPT4S0504I2
4	4.0	8.0-9.5	500	RPT4S0506I2
4-	4.8	1.6-3.2	500	RPT4S0602I2
6	4.8	4.8-6.4	500	RPT4S0604I2
5-	4.8	8.0-9.5	500	RPT4S0606I2
	4.8	9.5-12.7	500	RPT4S0608I2

INDUSTRY CODING COMPARISONS

SUPPLIER	CODE	SUPPLIER	CODE
BREMICK	RPT4S	POP	TSS
AJAX	73 STS	MARSON	BB

ALL STAINLESS STEEL 304 RIVETS

STAINLESS STEEL STEM - TRUSS HEAD

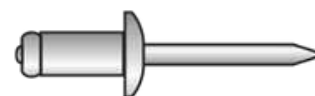

Size	Rivet Diameter (mm)	Grip Range (mm)	Pack Quantity	Product Code
4-2	3.2	1.6-3.2	1000	RPT440402I2
4-3	3.2	3.2-4.8	1000	RPT440403I2
4-4	3.2	4.8-6.4	1000	RPT440404I2
4-6	3.2	8.0-9.5	1000	RPT440406I2
4-8	3.2	9.5-12.7	1000	RPT440408I2
5-2	4.0	1.6-3.2	1000	RPT440502I2
5-3	4.0	3.2-4.8	1000	RPT440503I2
5-4	4.0	4.8-6.4	1000	RPT440504I2
5-5	4.0	6.4-8.0	1000	RPT440505I2
5-6	4.0	8.0-9.5	1000	RPT440506I2
5-6	4.0	1.6-3.2	500	RPT440506I2
6-2	4.8	3.2-4.8	500	RPT440602I2
6-3	4.8	4.8-6.4	500	RPT440603I2
6-4	4.8	6.4-8.0	500	RPT440604I2
6-4	4.8	8.0-9.5	500	RPT440605I2
6-5	4.8	9.5-12.7	500	RPT440606I2
6-6	4.8	12.7-15.8	500	RPT440608I2
6-8	4.8		500	RPT440610I2
6-10	4.8		500	RPT440610I2

INDUSTRY CODING COMPARISONS

SUPPLIER	CODE	SUPPLIER	CODE
BREMICK	RPT4S	POP	TSS
AJAX	73 STS	MARSON	BB

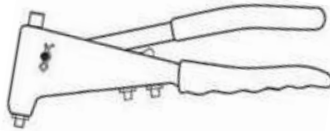

**BREMICK HAND TOOL - BHT**

**DIAMETER CAPACITY**

No.	Inch	mm	Material
4	1/8	3.2	All Materials
5	5/32	4.0	All Materials
6	3/16	4.8	Aluminium/Steel Sealed

**TOOL**

Tool	Product Code	Notes
BHT	TRTBHT00000	

**BHT HAND TOOL SPARE PARTS LIST**

Position	Product Description	Product Code
1	Nose piece 3.2mm/(1/8)	TRTPBHT0012
2	Nose Piece 4.0mm/(5/32)	TRTPBHT0022
3	Nose Piece 4.8mm/(3/16)	TRTPBHT0032
4	Jaws (set of 2)	TRTPBHT0042
5	Jaw Case	TRTPBHT0052
6	Jaw Pusher	TRTPBHT0062
7	Jaw Pusher Spring	TRTPBHT0072
8	Jaw Assembly Screw	TRTPBHT0082
9	Body	TRTPBHT0092
10	Body Grip	TRTPBHT0102
11	Lever	TRTPBHT0112
12	Lever Grip	TRTPBHT0122
13	Nose Piece Spanner	TRTPBHT0132
14	Pulling Arm	TRTPBHT0142
15	Pulling Arm Pin	TRTPBHT0152
16	Body Pins (2)	TRTPBHT0162
17	Body Pin Clips (2)	TRTPBHT0172

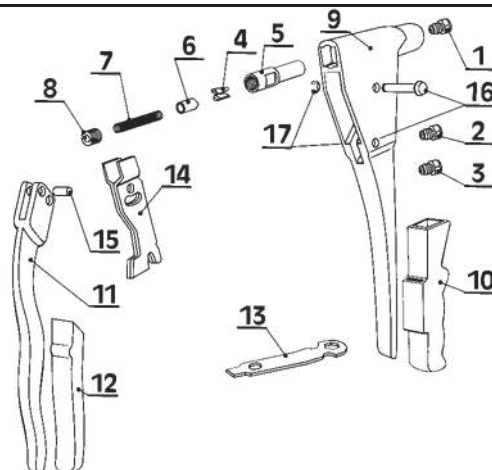

Lightweight 0.6kg.  
 Tradesman & home handyman quality.  
 Rivet capacity as indicated.

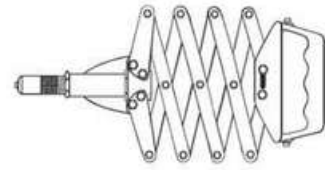
**BREMICK LAZY TONG TOOL - BLT****DIAMETER CAPACITY**

No.	Inch	mm	Material
4	1/8	3.2	All Materials
5	5/32	4.0	All Materials
6	3/16	4.8	All Materials
8	1/4	6.4	All Materials

**TOOL**

Tool	Product Code	Notes
BLT	TRTBLT00000	

**BLT HAND TOOL SPARE PARTS LIST**

Position	Product Description	Product Code
1	Nose piece 3.2mm/(1/8)	TRTPBLT0012
2	Nose Piece 4.0mm/(5/32)	TRTPBLT0022
3	Nose Piece 4.8mm/(3/16)	TRTPBLT0032
4	Jaws (set of 2)	TRTPBLT0042
5	Jaw Case	TRTPBLT0052
6	Jaw Pusher	TRTPBLT0062
7	Jaw Pusher Spring	TRTPBLT0072
8	Jaw Assembly Screw	TRTPBLT0082
9	Body	TRTPBLT0092
10	Body Grip	TRTPBLT0102
11	Lever	TRTPBLT0112
12	Lever Grip	TRTPBLT0122
13	Nose Piece Spanner	TRTPBLT0132
14	Pulling Arm	TRTPBLT0142
15	Pulling Arm Pin	TRTPBLT0152
16	Body Pins (2)	TRTPBLT0162
17	Body Pin Clips (2)	TRTPBLT0172

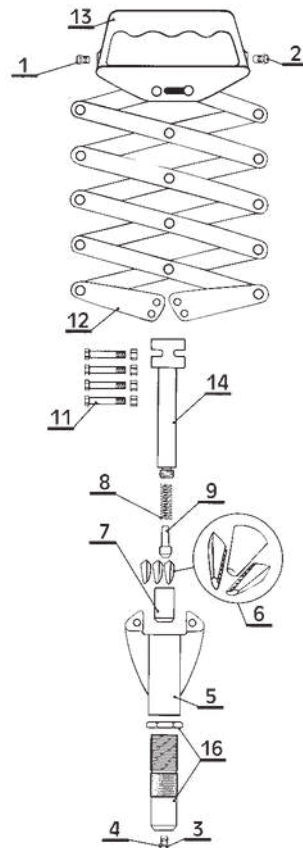

Weight 2.2 KG

Rivet Capacity as indicated

**Main Feature:**

The tool has an adjustable stroke so that you can maximise its mechanical advantage and minimise the time to set a rivet. To best take advantage of this feature:-

**1) Set a test rivet.**

- If the rivet stem breaks early in the stroke, the stroke is too long.
- If the rivet does not break in one stroke, the stroke is too short.

**2) Adjust stroke.**

- If stroke too long, screw the Nosebody in to reduce the stroke.
- If stroke too short, screw the Nosebody out to increase the stroke.



DIAMETER DRILL SIZE

Thickness to be Riveted	Up Inch } to mm Diameter of Rivet	1/16	1/8	3/16	1/2	5/8	3/4
		1.6	2	4.8	12	16	19
<b>PLUG (Break)</b>	<b>Rivet</b>						
AS ALUMINIUM 5056 2S ALUMINIUM 5052 AA ALL ALUMINIUM SS STEEL	<b>No. 3 3/32</b>		<b>3-2</b>	<b>3-3</b>			
MS MONEL® ALLOY 4S STAINLESS STEEL 44 ALL STAINLESS	<b>No. 4 1/8</b> <b>No. 5 5/32</b> <b>No. 6 3/16</b>	4- 1 5-	4- 2 5-	4- 3 5-	4- 4 5-	4- 5 5-	4- 6 5-
<b>SEALED (Weatherproof)</b>	<b>Diameter of Rivet</b>	6- 1	6- 2	6- 3	6- 4	6- 5	6- 6
<b>ST ALUMINIUM</b>	<b>No. 4 1/8</b> <b>No. 5 5/32</b> <b>No. 6 3/16</b>		<del>8-</del> 2 5-	4- 3 5-	<del>8-</del> 4 5-	4- 5 5-	<del>8-</del> 6 5-

RIVET MATERIALS

- AS** Aluminium Rivet Grade 5056  
Steel Stem Zinc Plated
- 2S** Aluminium Rivet  
Grade 5052
- AA** Aluminium Rivet Grade 5052  
Aluminium Stem
- SS** Steel Rivet Zinc Plated 1010  
Steel Stem Zinc Plated
- MS** Monel® Rivet  
Steel Stem Zinc Plated
- 4S** Stainless Steel Rivet Grade 304 HQ  
Steel Stem Zinc Plated
- 44** Stainless Steel Rivet Grade 304 HQ  
Stainless Steel Stem
- ST** Aluminium Sealed Rivet Grade 5056  
Steel Stem Oil Finish

2 3 4 5 6  
6- 6- 6- 6- 6-  
2 3 4 5 6

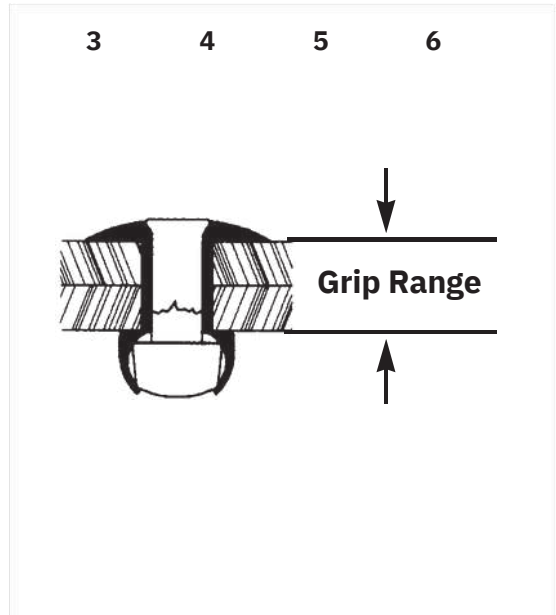

Monel® is a registered trade mark of Inco





DIAMETER DRILL SIZE (CONTINUED)

1/2	5/8	3/4	7/8	1	1.1/4	Rivet Diam.	Drill Size		
							mm	No.	In.
12.7	16	19	22.2	25.4	31.8				
						3/32	2.5	41	3/32
4-	4-	4-12				1/8	3.	3	1/8
8	10					5/32	3	0	5/32
5-	5-	6-	6-	6-16	6-20	2	4.	2	3/16
8	10	12	14			3/4	1	0	1/4
6-	6-	8-	8-			6	4.	1	
8	10	12	14				9	1	
8-	8-					1/8	0.	3	1/8
8	10					5/32	5/32	0	5/32
6-8	6-10					2	4.	2	3/16
						3/1	1	0	
						6	4.	1	
							9	1	

HEAD AND RIVET TYPES

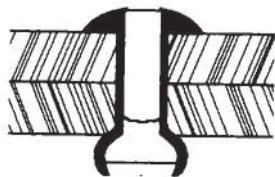

**TRUSS HEAD  
PLUG**

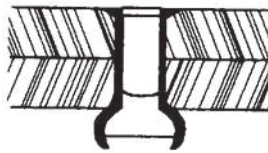

**COUNTERSUNK  
HEAD PLUG**

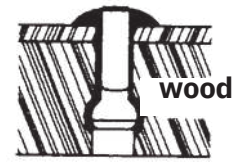

**GROOVED  
RIVET**  
Grooves improve  
holding strength



**SEALED**  
End of rivet is sealed  
for weatherproofing

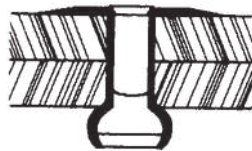

**LARGE FLANGED  
RIVET PLUG**



**MULTI-GRIP  
PLUG**  
One rivet does a  
number of grip ranges



SIZE IDENTIFICATION CHART AND CODE COMPARISON

	SIZE CODE		Typical Body Length mm		SIZE CODE		Typical Body Length mm
	Pop	Bremick/Cherry			Pop	Bremick/Cherry	
	33	3-2	5.5		62 624	6-1	6.3
	36	3-3	7.0		64 624	6-2	7.9
	42 419	4-1	4.7		66 630	6-3	9.5
	44 424	4-2	6.3		68 639	6-4	11.0
	46 429	4-3	7.9		610	6-5	12.6
	48 435	4-4	9.5		61	6-6	14.2
	410 440	4-5	11.1		2 65	6-8	17.9
	412	4-6	12.7		66	6-10	21.1
	416	4-8	16.4		5	6-12	24.2
	421	4-10	20.1		625 615	6-14	27.4
	425	4-12	23.3		7 67	6-16	30.6
	52 519	5-1	5.5		633	6-20	36.0
	54 524	5-2	7.1		6150	8-4	12.6
	56 530	5-3	8.7		88	8-6	15.8
	58 537	5-4	10.3		812	8-8	19.0
	510 545	5-5	11.9		816	8-10	22.1
	512	5-6	13.5		-	8-12	25.3
	516	5-8	17.1		824	8-14	28.4
					-	8-16	31.0

**MECHANICAL PROPERTIES - RIVET MATERIAL COMPATIBILITY**

RIVET MATERIAL	MATERIAL TO JOIN					
	Aluminium	Copper	Steel	Copper - Nickel	Stainless Steel	Brass
Aluminium	++	-	+	+-	++	-
Copper	-	++	-	++	+	++
Steel	+	-	++	+	++	-
Copper - Nickel	+-	++	+	++	++	++
Stainless Steel	++	+	++	++	++	++
Nickel - Copper	+-	+	++	++	+	++

- not compatible

+ good compatibility

++ very good compatibility

+- **Compatible in rural and mild environments**

Some corrosion may occur in marine / industrial environments.

Painting both metals would reduce reaction.

**THIS TABLE IS INTENDED FOR GUIDANCE ONLY**

The data may vary depending on both atmosphere and temperature.



### MECHANICAL PROPERTIES (CHARACTERISTIC CAPACITY)

Nominal Rivet Size	Aluminium 5056, Plug Style				Aluminium 5056, Sealed Style			
	Minimum Shear Strength		Minimum Tensile Strength		Minimum Shear Strength		Minimum Tensile Strength	
	N	lbs	N	lbs	N	lbs	N	lbs
No 3 3/32" 2.4mm	400	90	530	120	-	-	-	-
No 4 1/8" 3.2mm	760	170	980	220	1070	240	1240	280
No 5 5/32" 4.0mm	1160	260	1560	350	1560	350	2130	480
No 6 3/16" 4.8mm	1690	380	2220	500	2220	500	3070	690
No 8 1/4" 6.4mm	3110	700	4090	920	-	-	-	-

Nominal Rivet Size	Zinc Plated Steel 1010, Plug Style				Stainless Steel, Plug Style			
	Minimum Shear Strength		Minimum Tensile Strength		Minimum Shear Strength		Minimum Tensile Strength	
	N	lbs	N	lbs	N	lbs	N	lbs
No 4 1/8" 3.2mm	1100	260	1200	310	1900	420	2500	530
No 5 5/32" 4.0mm	1700	370	2200	470	2700	650	3500	820
No 6 3/16" 4.8mm	2900	540	3100	680	4000	950	5000	1200
No 8 1/4" 6.4mm	4900	1000	5700	1240	-	-	-	-

Nominal Rivet Size	Monel® Plug Style				Aluminium & All Aluminium 5052, Plug Style			
	Minimum Shear Strength		Minimum Tensile Strength		Minimum Shear Strength		Minimum Tensile Strength	
	N	lbs	N	lbs	N	lbs	N	lbs
No 4 1/8" 3.2mm	1560	350	2000	450	530	120	670	150
No 5 5/32" 4.0mm	2450	550	3110	700	850	190	1020	230
No 6 3/16" 4.8mm	3560	800	4450	1000	1160	260	1420	320

Monel® is a registered trademark of INCO Family of Companies.